

# Geka™ Ironworkers

Geka™

Model	Punch	Die
11 H	219	417
13 H	219	417
16 H	221	417
20 H	221	417
25 H	228	421
55A	221	417
80A	221	417
Bendicrop 50	221	417
Bendicrop 60	221	417
Bendicrop 85	221	417
CEP 11	219	417
CEP 13	219	417
CEP 16	221	417
CEP 20	221	417
H 85 S	221	417
Hydracrop 50	219	417
Hydracrop 55A	221	417
Hydracrop 70	219	417
Hydracrop 100	221	417
Hydracrop 110	221	417
Hydracrop 150	228	421
Hydracrop 165	228	421
Hydracrop 200	228	421
Hydracrop 220	228	421
Maxicrop	219	417
Microcrop	219	417
Minicrop	219	417
Multi 11	208	405
Puma 11	219	417
Puma 13	219	417
Puma 16	221	417
Puma 20	221	417
Puma 50H	219	417
Puma 55H	221	417
Puma 70H	219	417
Puma 80 Dual Static	221	417
Puma 100H	221	417
Puma 110A	221	417
Puma 110H	221	417
Puma 150H	228	421
Puma 165H	228	421
Puma 200H	228	421
Puma 220H	228	421

## PUNCHES

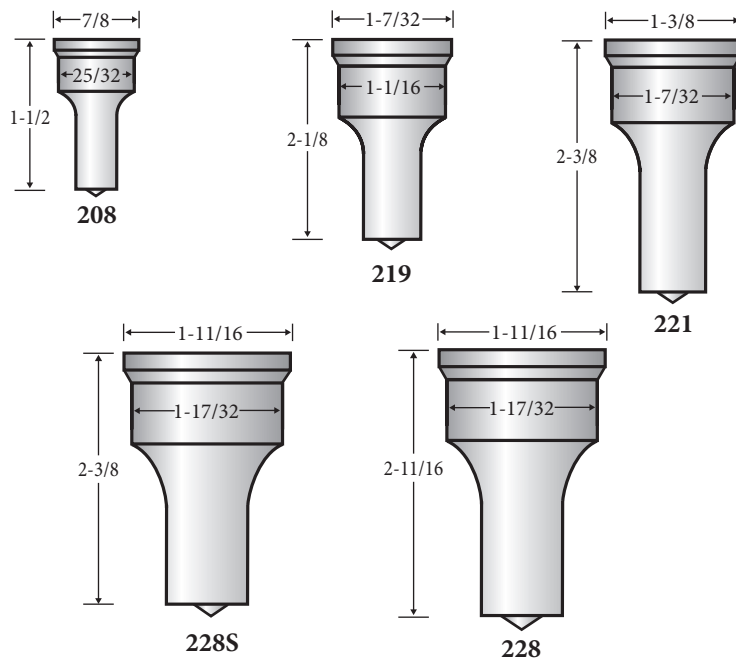

## OVERSIZE

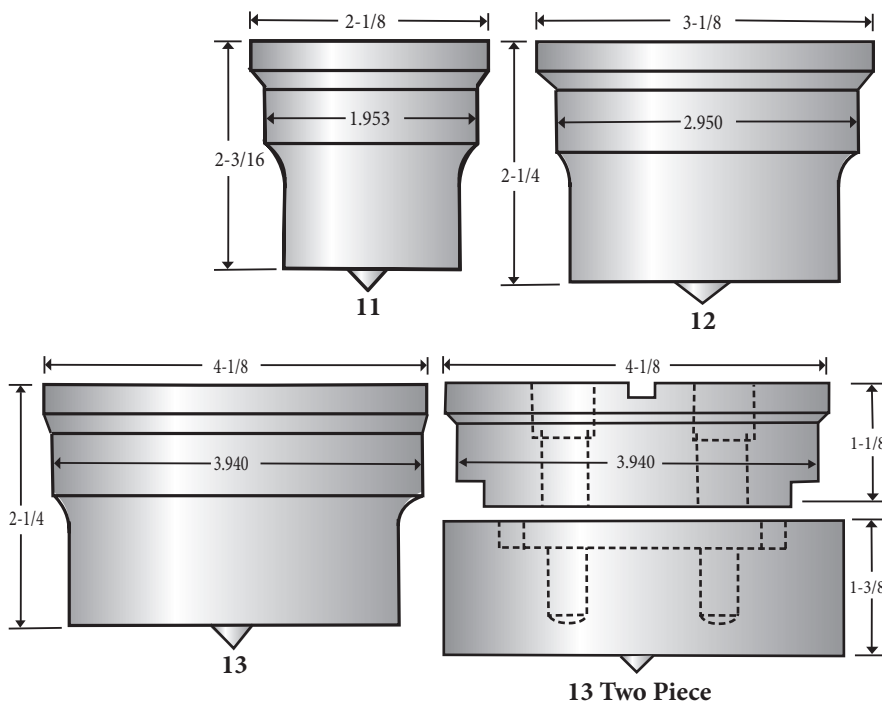

**Note:** Geka™ Ironworkers use Punch Style 228 or 228 Short, 11, 12, 13, (13 Two Piece) or Die Style 421, 11, 12, 13, 60mm or 200mm for Oversize Hole Punching.

Geka™ Ironworkers use 4mm x 2mm or 6mm x 3mm Keyways and Whistle Spots for alignment of shaped punches and dies.



# Geka™ Ironworkers

## DIES

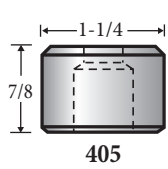

405

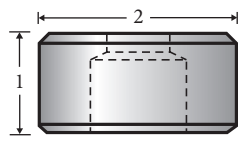

417

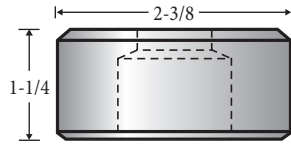

419

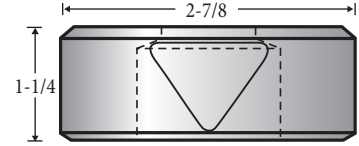

421

## OVERSIZE DIES

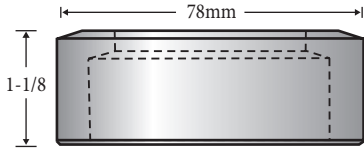

11

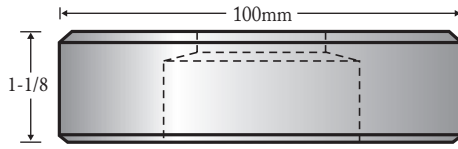

12

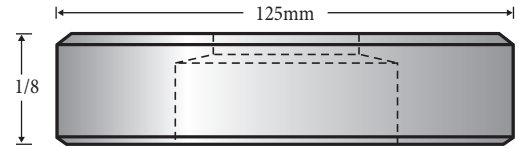

13

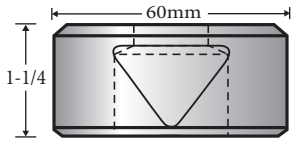

60mm

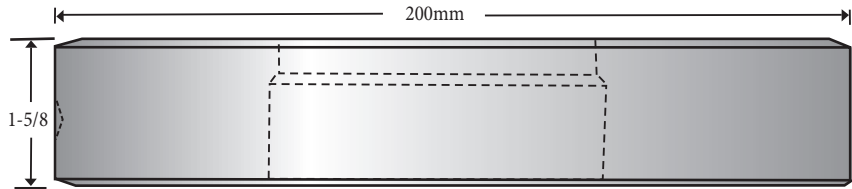

200mm

## GEKA OFFSET TOOLING

228 Offset Insert Holder

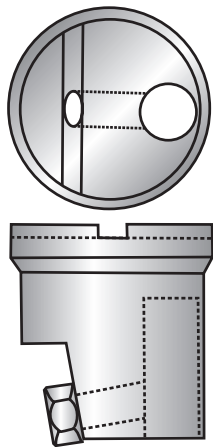

Punch Insert



Die Insert

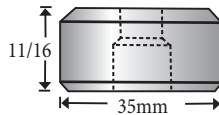

60mm Offset Die Holder

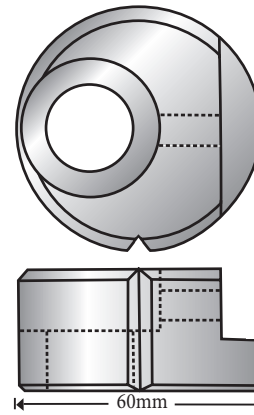

## SHEAR BLADES

We manufacture Shear Blades for all types of Ironworkers and can custom manufacture to your specifications.

