



CLEVELAND STEEL TOOL

Multi-Shear

Multiple Shearing Attachment

Shear Type	Capacity
Flat Bar Shear	1/4" x 6"
Angle Shear	2" x 2" x 1/4"
Distortion Free Round Rod Shear	1/4", 3/8", 1/2", 5/8, 3/4"
Distortion Free Square Rod Shear	up to 13/16"

Available to fit any shop press with a
minimum 20 ton capacity,
8" open height
and 7/8" stroke.

Mounting bases available for a
variety of machines.

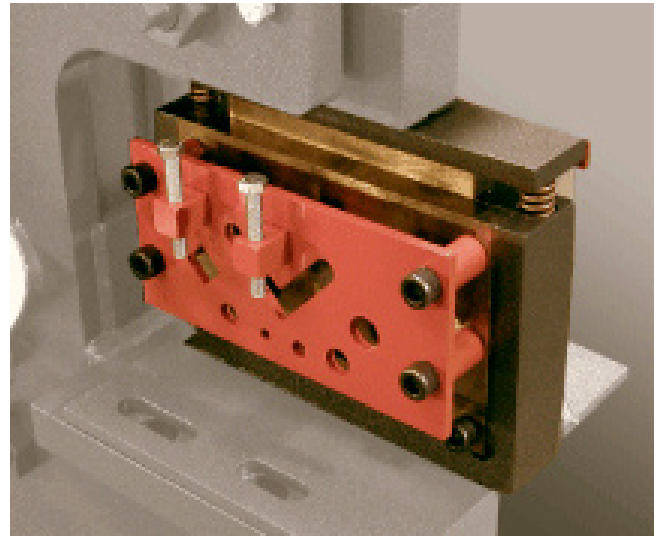
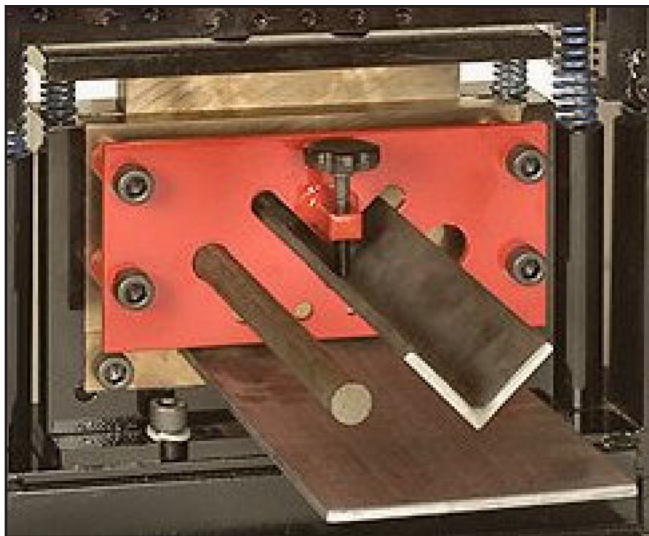

25 Ton Ironworker

Technical Specifications	
Rated capacity <small>**Rated at 65,000 psi tensile strength</small>	25 Ton
Number of work stations	2
Throat depth	5-1/2"
Maximum capacity	1" dia. thru 1/4" plate
Largest standard punch	1-1/16" punch
Largest standard die	1-1/4" die
Open height	Front 6", Back 8"
Closed height	Front 5", Back 7"
Stroke	1"
Table size	6" x 10"
Hydraulic system	3 gallon reservoir 2,200 PSI, 1-3/4 Ram
Standard motor	1 HP, single phase 110V - 7 amps
Optional motors	1 HP, single phase, 208/220V 14 amps
Dimensions	Base - 29" W x 32" L x 55" H
Shipping Weight	1,000 lbs.

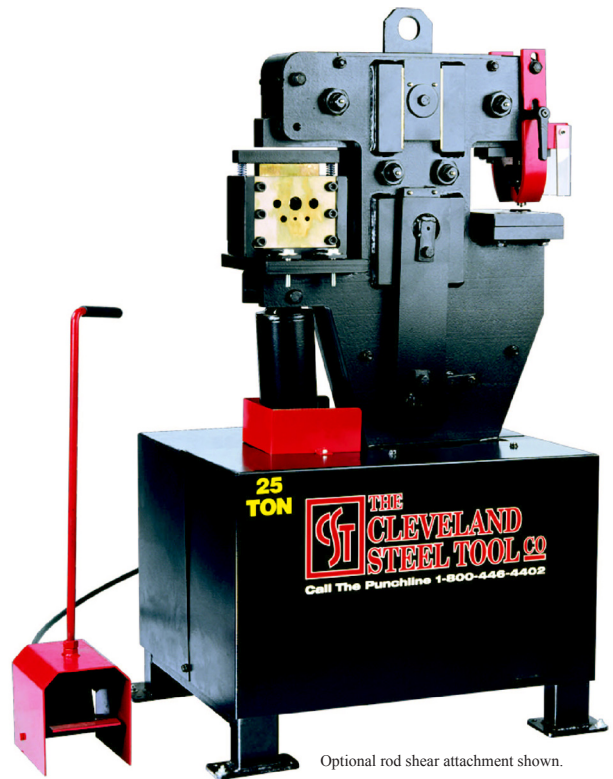

Optional rod shear attachment shown.

Casters available for mobility on the shop floor.

Standard Features

- Fully guarded • Adjustable steel strippers
- Integral lifting lug for instant portability • Direct drive pump
- Fully charged hydraulic system • Gauge table
- Electric stroke control • Remote foot pedal operation
- Open station for optional tooling

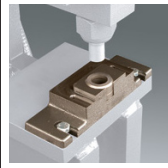
Punch Station with pedestal die table		219 Punch 413 Die
---------------------------------------	---	----------------------

Optional Attachments

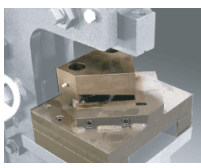
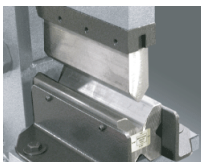
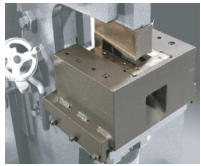
Optional Attachment		Capacity
Angle Notcher		2" x 2" x 1/4" mild steel
Brake		7" 1/4" mild steel
Coper Notcher		2" x 3" x 5/16" mild steel

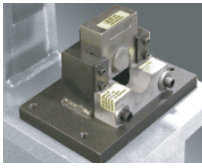
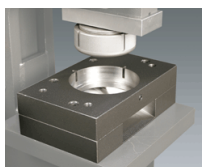
Optional Attachment		Capacity
Pipe Notcher		Up to 2" OD (Schedule 40 pipe)
Oversize Punching Attachments		228 Punch-419 Die Sizes up to 1-1/2" rd thru 3/16" thick mild steel 241 Punch-28XX Die (shown) sizes up to 3-1/2" rd thru 12 gauge mild steel

CST CLEVELAND STEEL TOOL

800-446-4402 • www.clevelandsteeltool.com

474 E. 105th St. • Cleveland, OH 44108

All specifications are subject to change. 8-09