

Headed Punch Styles

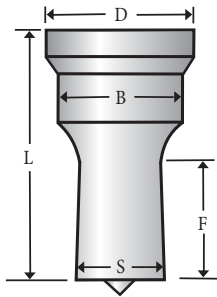

- D** = Head Diameter
- B** = Body Diameter
- L** = Overall length of punch
(not including center point)
- S** = Punch size (hole size)
- F** = Effective working length of punch
(determined by punch diameter)

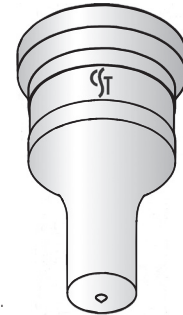

Note: All standard punches are supplied with a back taper unless otherwise specified. The thickness of the material should not exceed the punch diameter being used.

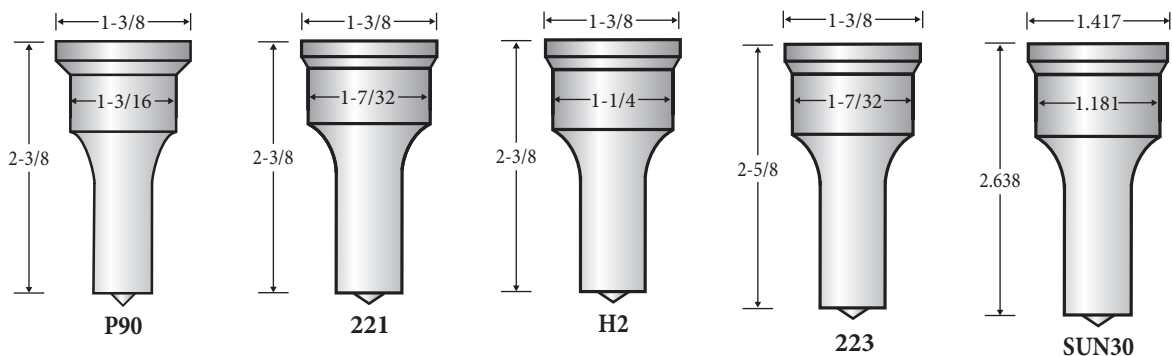
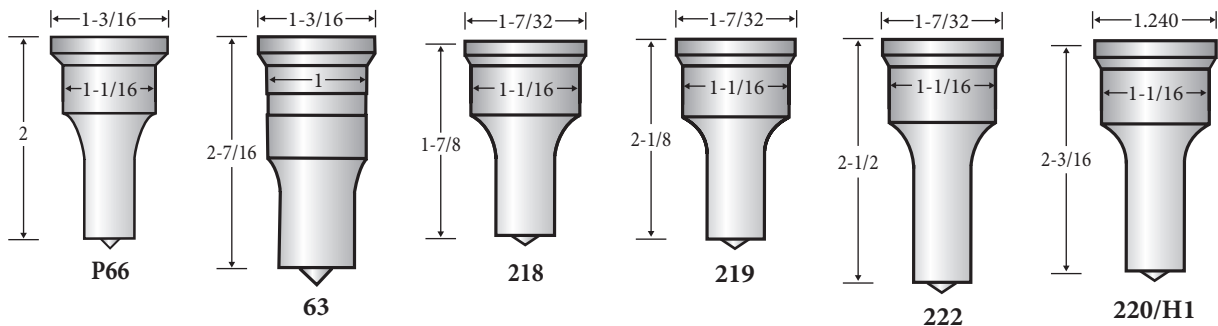
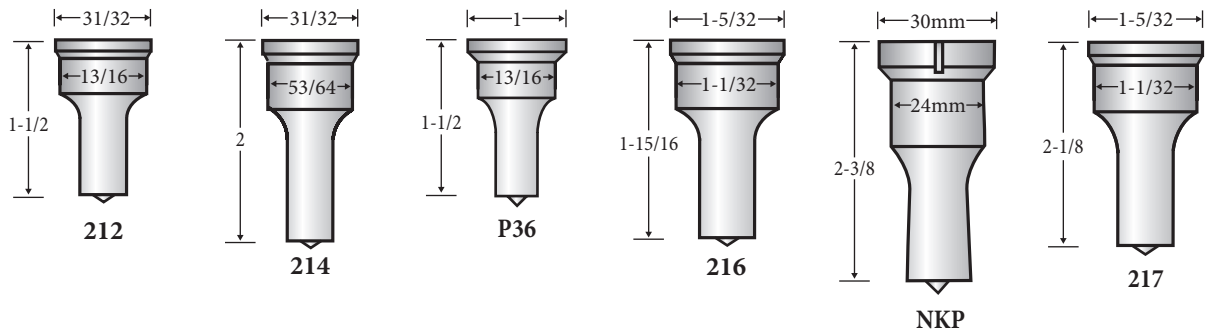
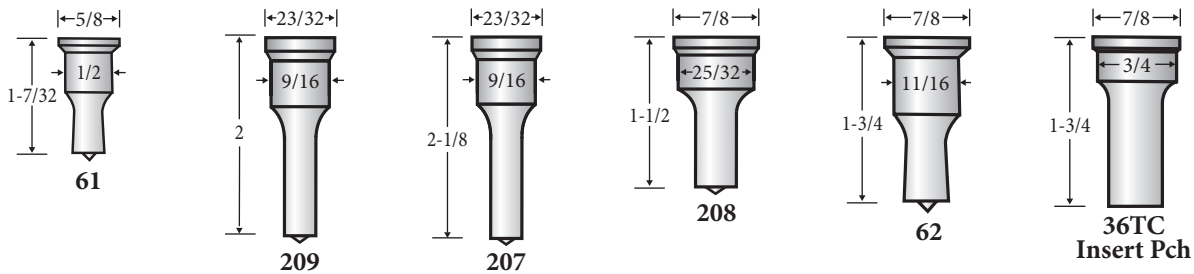

Headed Punch Styles



Headed Punch Styles

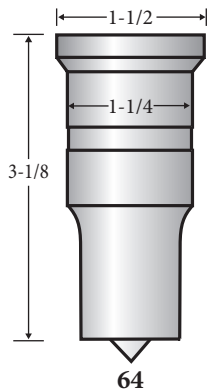

64

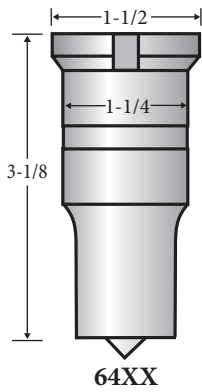

64XX

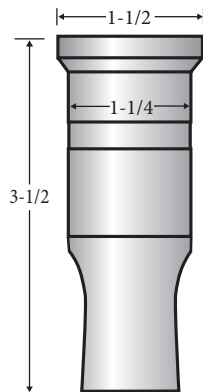

64XL

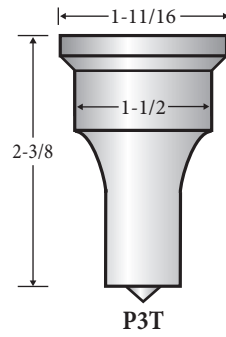

P3T

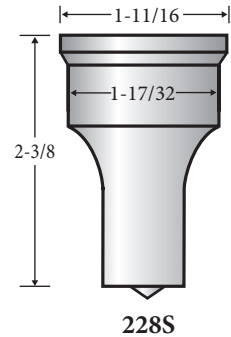

228S

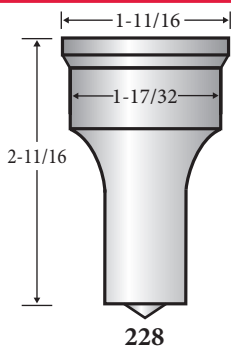

228

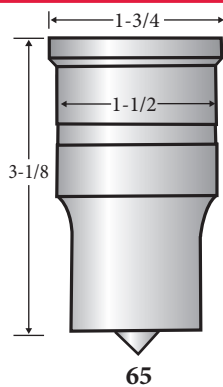

65

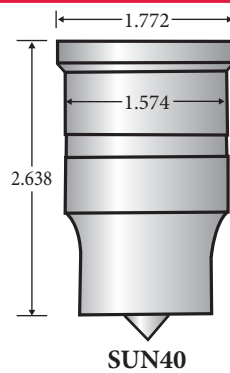

SUN40

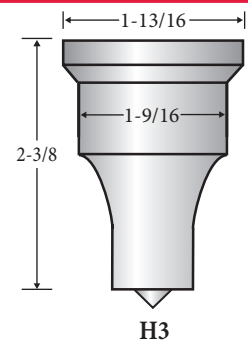

H3

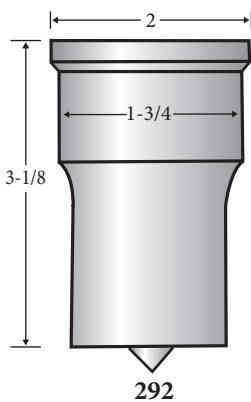

292

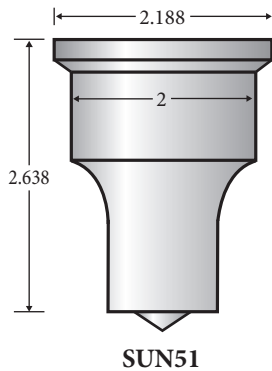

SUN51

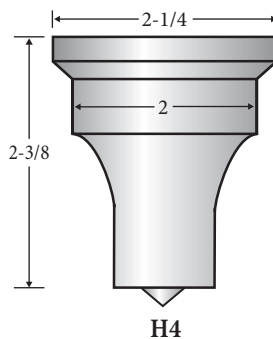

H4

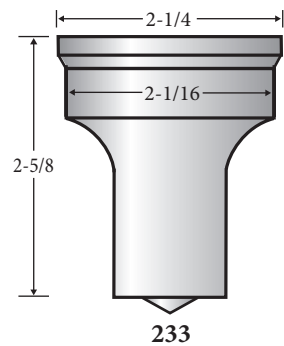

233

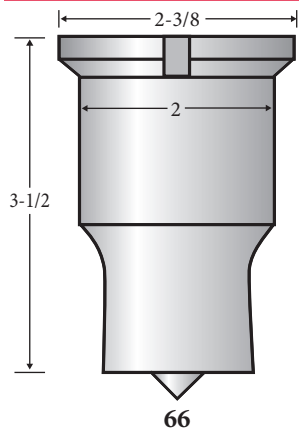

66

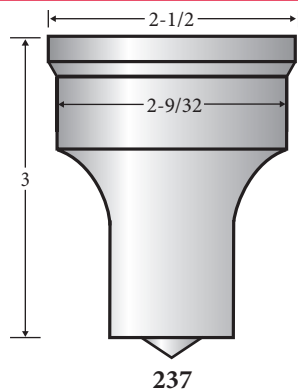

237

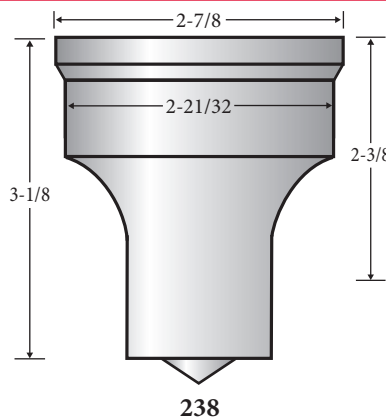

238

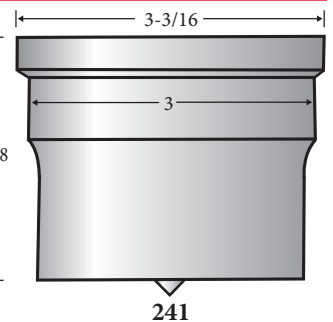

241

Headed Punch Styles