



Franklin™ Ironworkers

Model	Punch	Die
AFC5104	64	47
AFC5106	64	47
AFC5108	64	47
AFC5138	64	47
BL100-5	64	47
F530X3	63	48
F550X4	64	47
F570X6	64	47
F5100X6	64	47
F5125X6	66	46
F5175X12	66	46
F5175X6	66	46
F5275X12	66	46
PF196X72G	64	47
SF70A	64	47
W530X4	64	47
W550X7	64	47
W570X8	64	47
W5100X12	64	47
W5100X18	64	47
W5100X30	64	47
W51525X12	66	46
W5175X18	66	46

Note: Franklin™ Machines use Punch Style 66 and Die Style 46 for Oversize Hole Punching.

PUNCHES

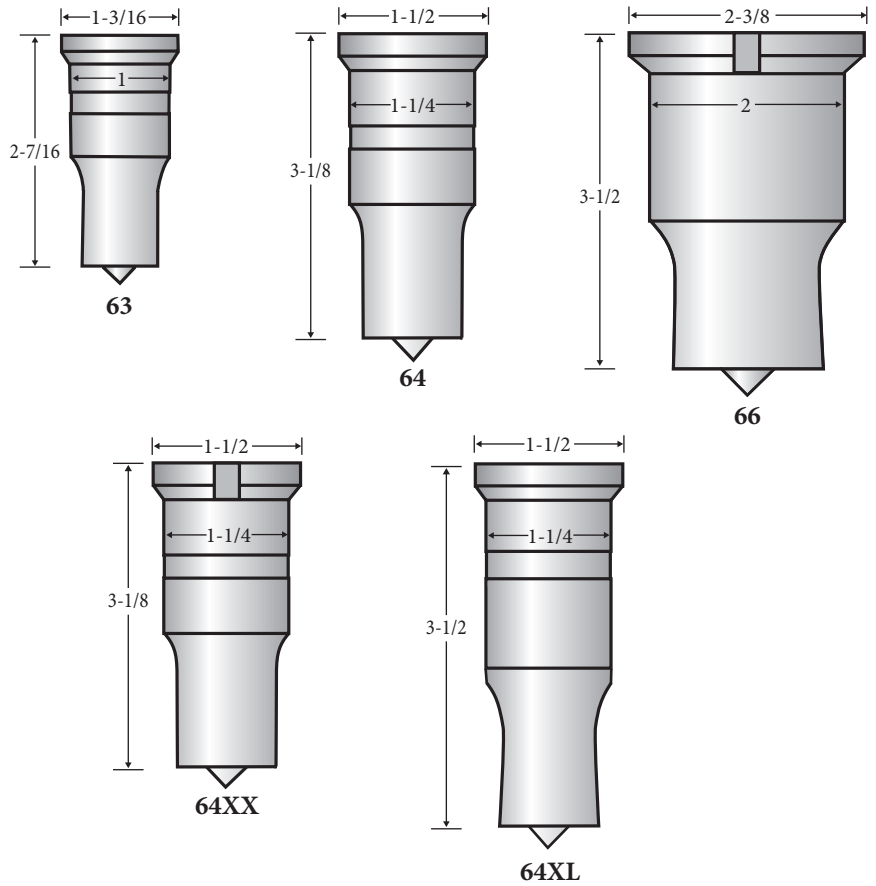

DIES

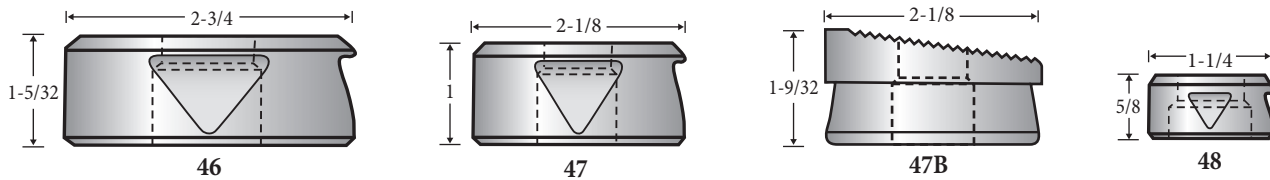

SHEAR BLADES

We manufacture Shear Blades for all types of Ironworkers and can custom manufacture to your specifications.

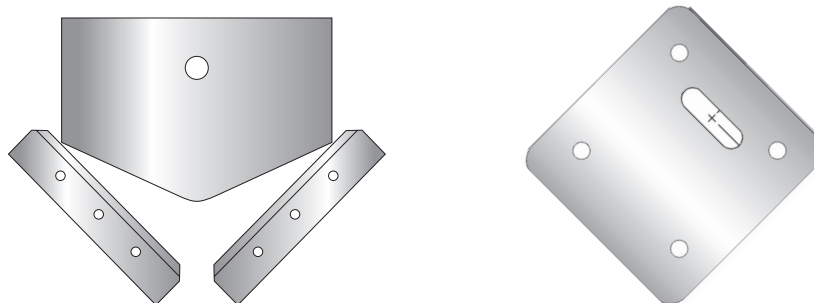

Franklin™