

All stock items are available for **immediate shipment.**

Non-stock sizes of a round, oblong, square, hexagonal and rectangular shape of standard tooling will be **shipped within 48 hours.**

NOTE: 36TC is a trademark of The W.A. Whitney Company. The Cleveland Steel Tool Company is not affiliated with nor related to The W.A. Whitney Company. The Cleveland Steel Tool Company does not produce or sell authorized W.A. Whitney products. The W.A. Whitney Company does not endorse or warrant Cleveland Steel Tool products.

Fabricating Centers

	Uses Punch	Uses Die
647 Plus, 647 Plus II, 647 ATC 661-60, 661-84 ATC, 661-84 661-96 ATC, 661-120	36TC™	36TC™

612, 613, 615, 625, 626 627, 630, 635, 637, 647 650, 652, 653, 655, 656, 791-AX18 1524, 2120, 2330, 2530 2548	28XX	28XX
---	------	------

Portables

705	No. 61	No. 49
710, 720, 720X4, 720X6, 721	No. 62	No. 48
710CC	No. 62	No. 49
730CC, 730X8CC, 731	No. 63	No. 48
730, 730X8, 750, 751	No. 63	No. 47
750AX6, 751AX7, 771AX9, 790AX6 791AX18, 791AX30	No. 64 No. 64XX	No. 47 No. 47XX
770, 771, 790, 791, 791X18	No. 64	No. 47
7150AX6, 7151AX12	No. 64 No. 64XX No. 66	No. 46
7150AX12	No. 64 No. 64XX No. 66	No. 45
7250AX12	No. 66	No. 45

845 Anglematic
796 Beamline
7130-60 Plate Duplicator

No. 64, No. 64XX No. 47XX

36TC Punches

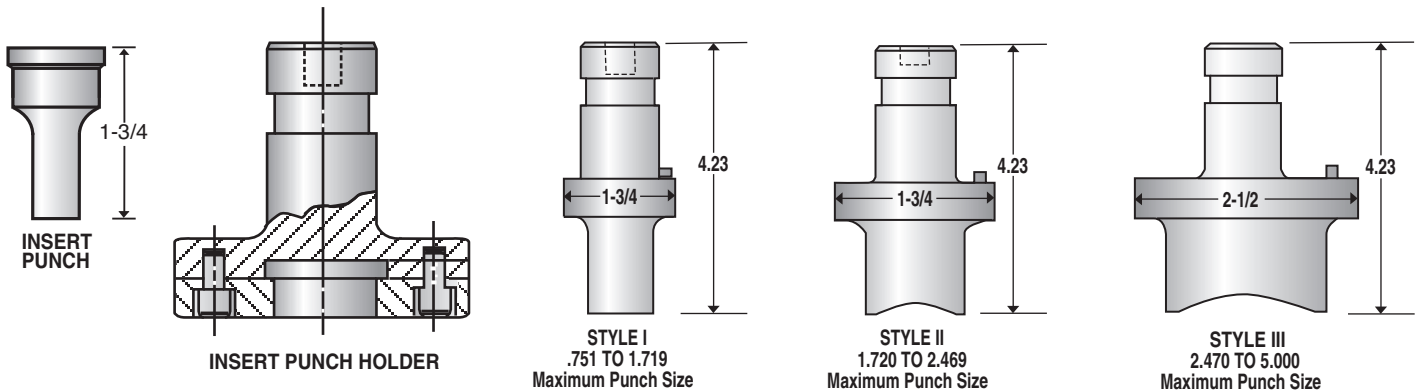

Orientation for shaped punches and dies is not limited to 90°. Diagram shows various angles of orientation possible.

(Continued on next page)

All stock items are available for **immediate shipment.**

Non-stock sizes of a round, oblong, square, hexagonal and rectangular shape of standard tooling will be **shipped within 48 hours.**

NOTE: 36TC is a trademark of The W.A. Whitney Company. The Cleveland Steel Tool Company is not affiliated with nor related to The W.A. Whitney Company. The Cleveland Steel Tool Company does not produce or sell authorized W.A. Whitney products. The W.A. Whitney Company does not endorse or warrant Cleveland Steel Tool products.

Fabricating Centers	Uses Punch	Uses Die
647 Plus, 647 Plus II, 647 ATC 661-60, 661-84 ATC, 661-84 661-96 ATC, 661-120	36TC™	36TC™
612, 613, 615, 625, 626 627, 630, 635, 637, 647 650, 652, 653, 655, 656 1524, 2120, 2330, 2530 2548	28XX	28XX
Portables		
705	No. 61	No. 49
710, 720, 720X4, 720X6, 721	No. 62	No. 48
710CC	No. 62	No. 49
730CC, 730X8CC, 731	No. 63	No. 48
730, 730X8, 750, 751	No. 63	No. 47
750AX6, 751AX7, 771AX9, 790AX6 791AX18, 791AX30	No. 64 No. 64XX	No. 47 No. 47XX
770, 771, 790, 791, 791X18	No. 64	No. 47
7150AX6, 7151AX12	No. 64 No. 64XX No. 66	No. 46
7150AX12	No. 64 No. 64XX No. 66	No. 45
7250AX12	No. 66	No. 45
845 Anglematic	No. 64	No. 47XX
796 Beamline	No. 64XX	
7130-60 Plate Duplicator		

36TC™ Dies

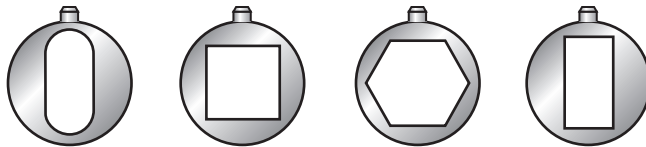
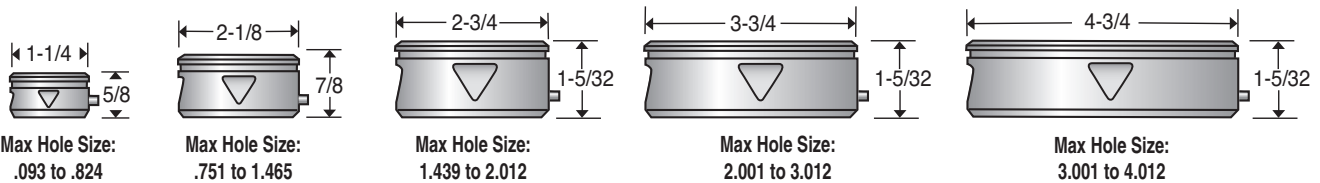

Standard Locating Pin Position on Shaped Punches and Dies

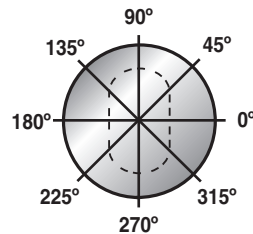

Front of Machine

Orientation for shaped punches and dies is not limited to 90°. Diagram shows various angles of orientation possible.

Quick Change Die Styles

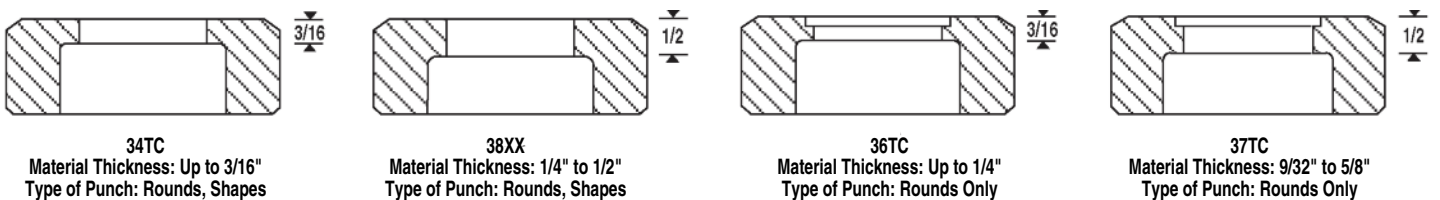

28XX Punches

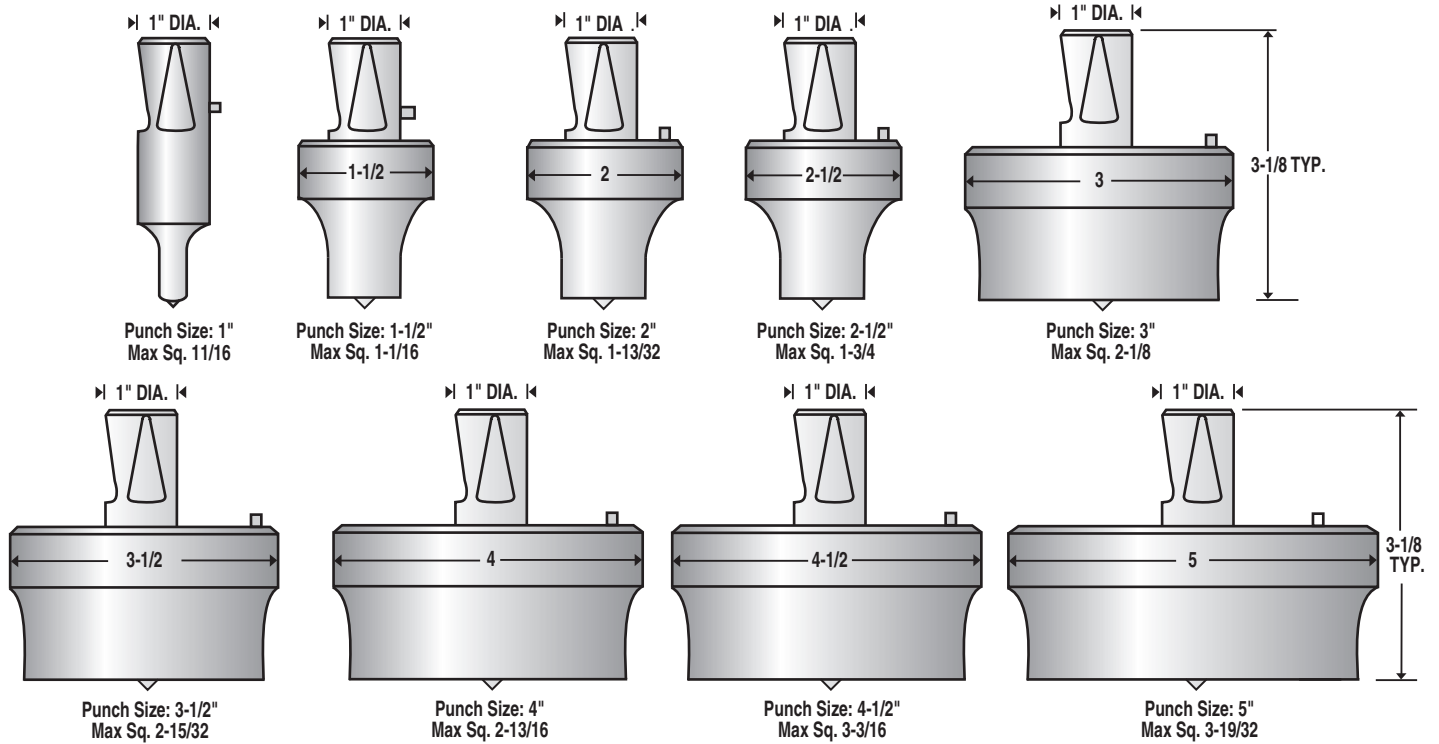

28XX Dies

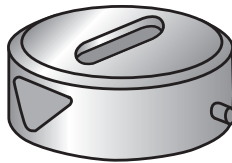
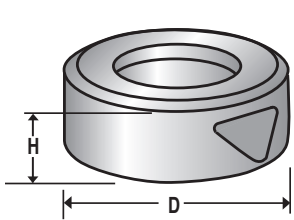

D	H
1-1/4	5/8
2-1/8	7/8
2-3/4	1-5/32
3-3/4	1-5/32
4-3/4	1-5/32
5-3/4	1-25/32

NOTE: Non-stock tooling in sizes up to 2" equivalent diameter can be shipped within 48 hours. Contact our sales department for price and availability for sizes over 2".

Standard Sq Punches

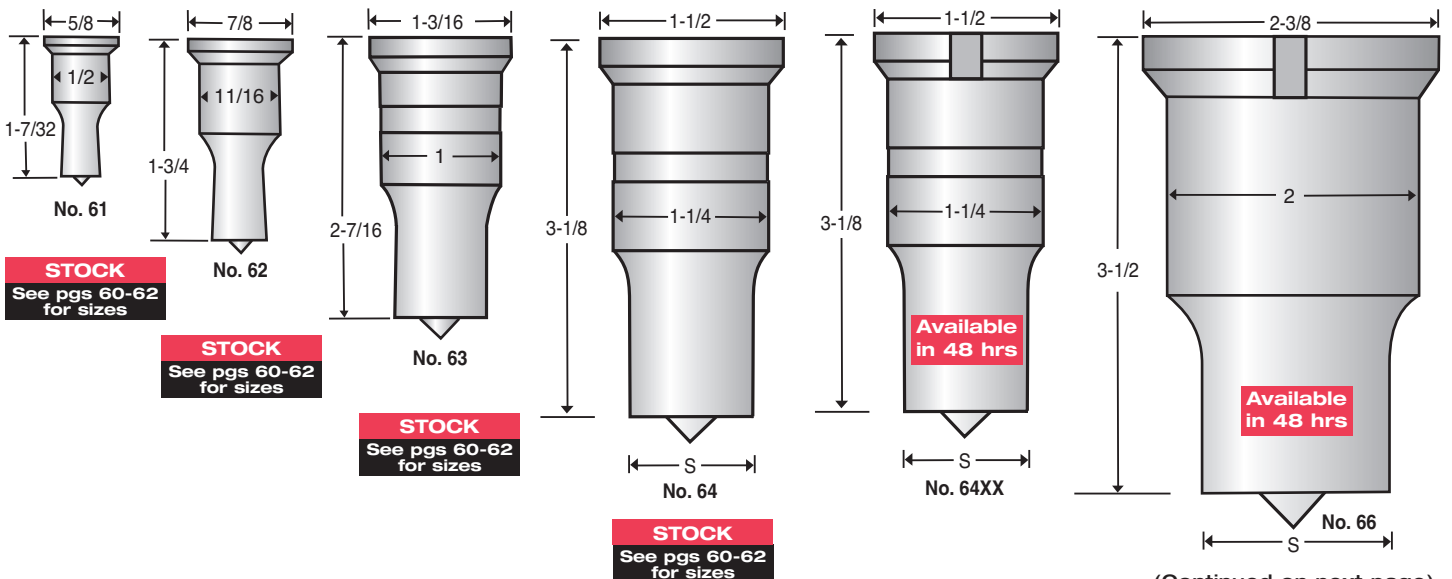

(Continued on next page)

All stock items are available for immediate shipment.

Non-stock sizes of a round, oblong, square, hexagonal and rectangular shape of standard tooling will be shipped within 48 hours.

NOTE: 36TC is a trademark of The W.A. Whitney Company. The Cleveland Steel Tool Company is not affiliated with nor related to The W.A. Whitney Company. The Cleveland Steel Tool Company does not produce or sell authorized W.A. Whitney products. The W.A. Whitney Company does not endorse or warrant Cleveland Steel Tool products.

Fabricating Centers	Uses Punch	Uses Die
647 Plus, 647 Plus II, 647 ATC 661-60, 661-84 ATC, 661-84 661-96 ATC, 661-120	36TC™	36TC™
612, 613, 615, 625, 626 627, 630, 635, 637, 647 650, 652, 653, 655, 656 1524, 2120, 2330, 2530 2548	28XX	28XX
Portables		
705	No. 61	No. 49
710, 720, 720X4, 720X6, 721	No. 62	No. 48
710CC	No. 62	No. 49
730CC, 730X8CC, 731	No. 63	No. 48
730, 730X8, 750, 751	No. 63	No. 47
750AX6, 751AX7, 771AX9, 790AX6 791AX18, 791AX30	No. 64 No. 64XX	No. 47 No. 47XX
770, 771, 790, 791, 791X18	No. 64	No. 47
7150AX6, 7151AX12	No. 64 No. 64XX No. 66	No. 46
7150AX12	No. 64 No. 64XX No. 66	No. 45
7250AX12	No. 66	No. 45
845 Anglematic	No. 64	No. 47XX
796 Beamline	No. 64XX	
7130-60 Plate Duplicator		

Standard Dies

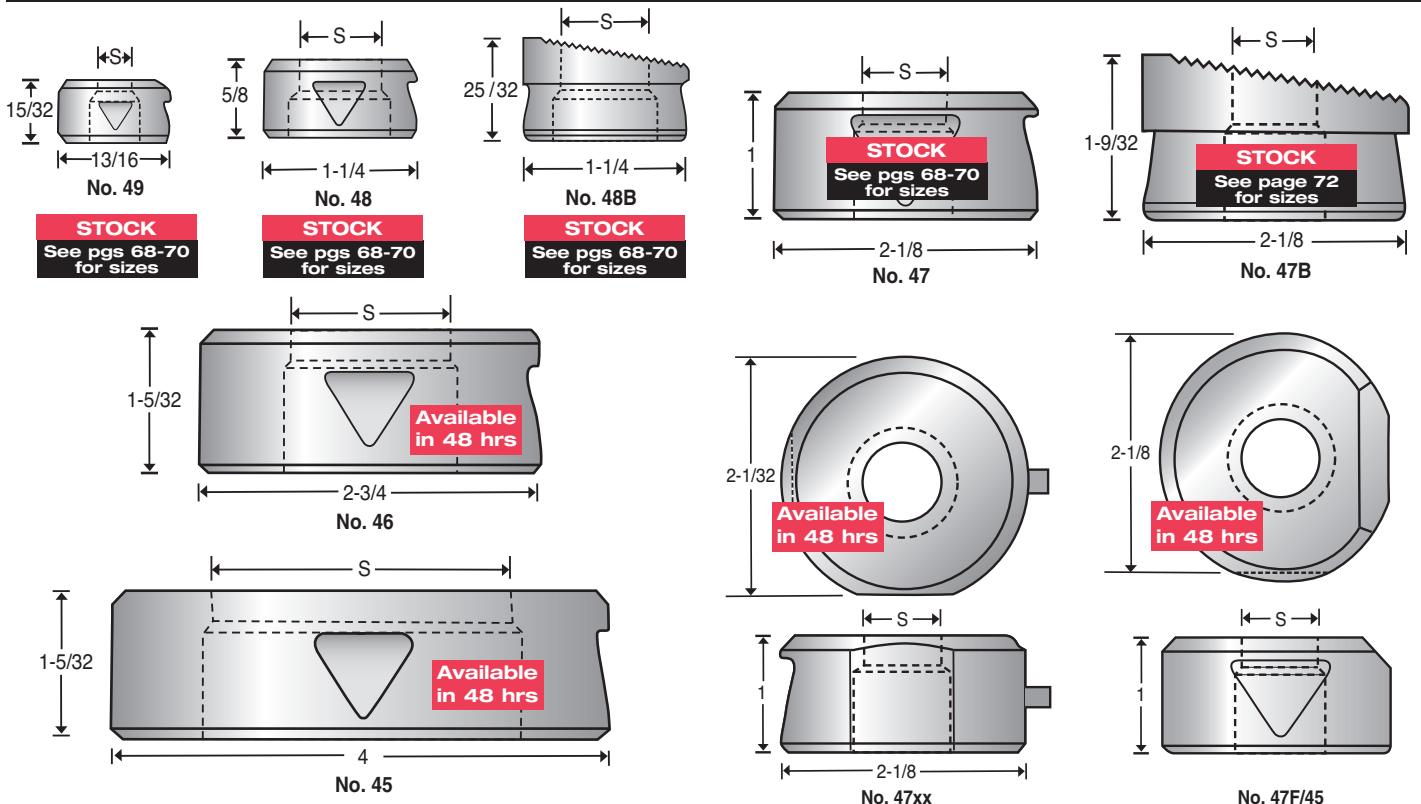

Shear Blades

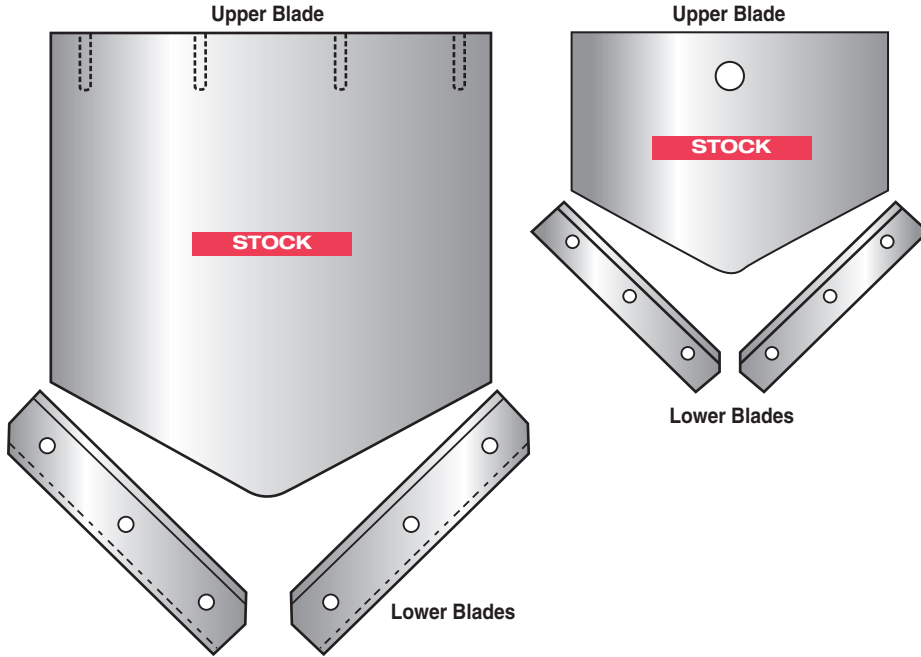

Stock Shear Blades

MODEL	UPPER SHEAR BLADE PART #	LOWER SHEAR BLADE PART #
606	C606-008	C606-010L (2) C606-113R (2)
609	C609-004	C609-039L (2) C609-040R (2)
664	C664-061	C609-039L (2) C609-040R (2)
764	C664-061	C609-039L (2) C609-040R (2)
765	C765-036	C765-032 (4)
845	C609-004	C845-269R (2) C845-270L (2)

Punch Coupling Nuts and Adapters

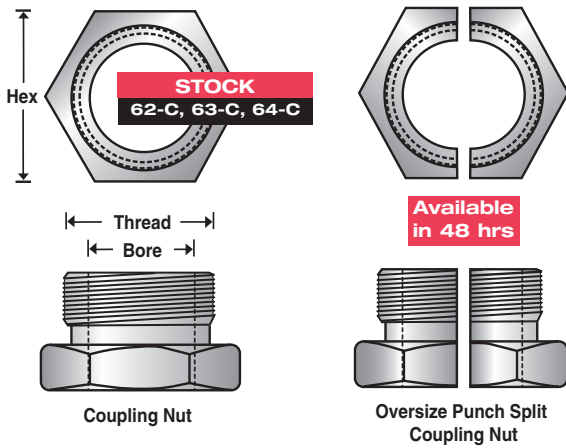

Stock Coupling Nuts

COUPLING NUT PART NO.	THREAD	BORE	HEX	FITS PUNCH
62-C	1", 16 UN	11/16"	1"	No. 62
63-C	1-3/8", 12NUF	1"	1-3/4"	No. 63
64-C	1-3/4", 12 UN	1-1/4"	2"	No. 64
C790-061	1-3/4", 12 UN	1-1/4"	2"	No. 64
C845-689	1-3/4", 12 UN	1-1/4"	1-9/16"	No. 64

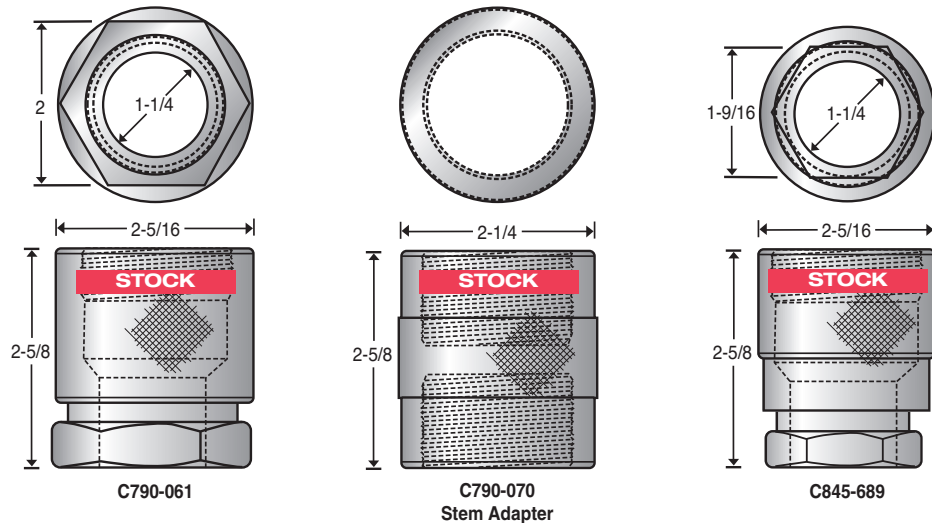

(Continued on next page)

All stock items are available for immediate shipment.

Non-stock sizes of a round, oblong, square, hexagonal and rectangular shape of standard tooling will be shipped within 48 hours.

NOTE: 36TC is a trademark of The W.A. Whitney Company. The Cleveland Steel Tool Company is not affiliated with nor related to The W.A. Whitney Company. The Cleveland Steel Tool Company does not produce or sell authorized W.A. Whitney products. The W.A. Whitney Company does not endorse or warrant Cleveland Steel Tool products.

Fabricating Centers	Uses Punch	Uses Die
647 Plus, 647 Plus II, 647 ATC 661-60, 661-84 ATC, 661-84 661-96 ATC, 661-120	36TC™	36TC™
612, 613, 615, 625, 626 627, 630, 635, 637, 647 650, 652, 653, 655, 656 1524, 2120, 2330, 2530 2548	28XX	28XX
Portables		
705	No. 61	No. 49
710, 720, 720X4, 720X6, 721	No. 62	No. 48
710CC	No. 62	No. 49
730CC, 730X8CC, 731	No. 63	No. 48
730, 730X8, 750, 751	No. 63	No. 47
750AX6, 751AX7, 771AX9, 790AX6 791AX18, 791AX30	No. 64 No. 64XX	No. 47 No. 47XX
770, 771, 790, 791, 791X18	No. 64	No. 47
7150AX6, 7151AX12	No. 64 No. 64XX No. 66	No. 46
7150AX12	No. 64 No. 64XX No. 66	No. 45
7250AX12	No. 66	No. 45
845 Anglematic	No. 64	No. 47XX
796 Beamline	No. 64XX	
7130-60 Plate Duplicator		

Punch Holder

Stock Punch Holders

28XX PUNCH HOLDER PART NO.	BAR CLAMP	WEAR BLOCK	SPACER
C637-086	C630-326	C630-327	C647-487
C652-065	N/A	N/A	N/A
C653-090	C630-326	C630-327	N/A
C828-319	N/A	N/A	N/A

Spacer

STOCK

Punch Holder

Wear Block

Bar Clamp

Miscellaneous Tooling

STOCK

Clamp Piston
C630-036

STOCK

Pivot Screw
C636-329

STOCK

Top Clamp
C636-262

Die Adapters and Pockets

Stock Die Adapters

DIE ADAPTER PART NO.	DIE DIAMETER	DIE CLAMP	DIE PIN
C636-381	1-1/4"	C630-268*	N/A
C636-382	2-1/8"	C630-269*	N/A
C636-436	2-3/4"	N/A	C636-604
C636-437	3-3/4"	N/A	C636-605
C636-438	4-3/4"	N/A	C636-606
C845-699	2-1/8"	N/A	N/A

*Uses C630-271 adapter screw.

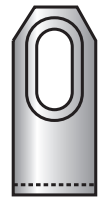
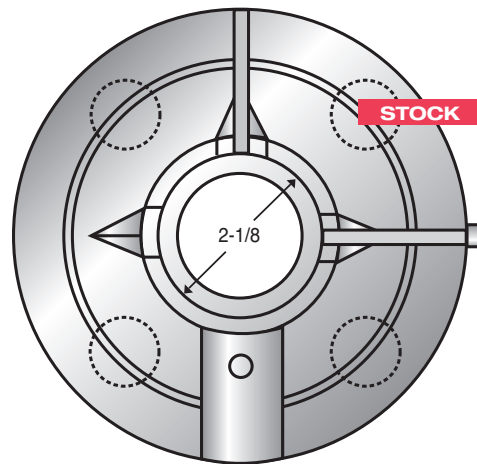

C630-268 Die Clamp

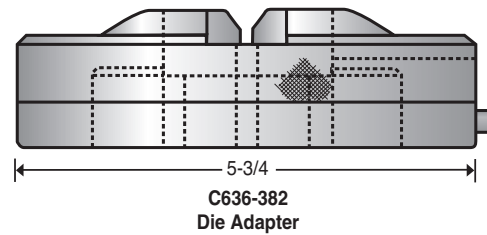

C636-382 Die Adapter

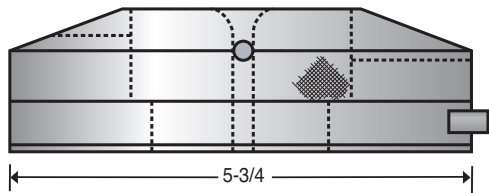
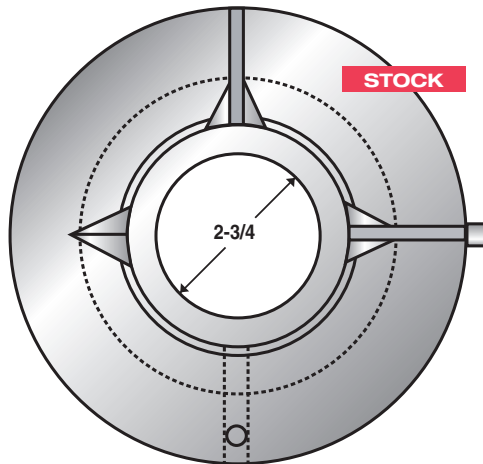

C636-436 Die Adapter



C363-604 Die Pin

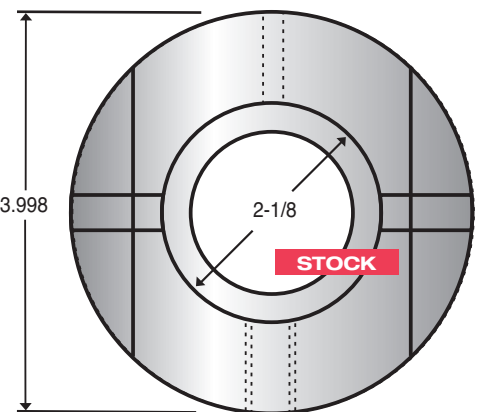

3.998

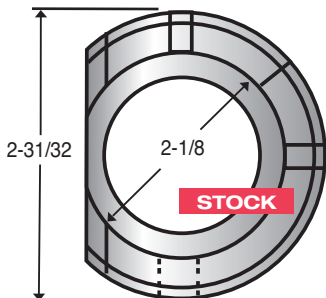

2-31/32

STOCK

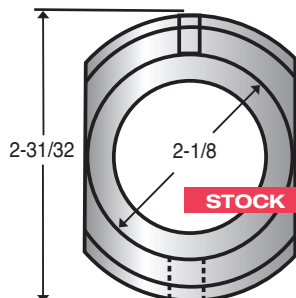

2-31/32

STOCK

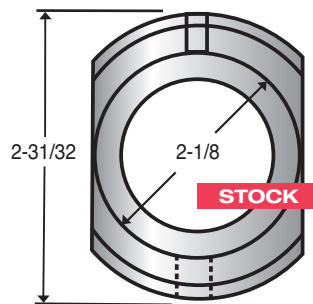

2-31/32

STOCK

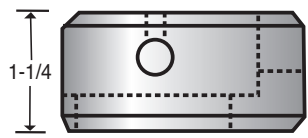

C790-379

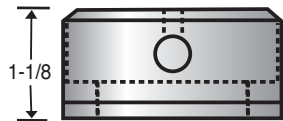

C791-059

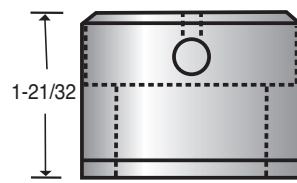

C791-037

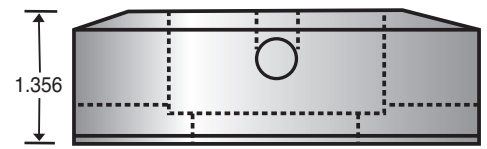

C845-699