

All stock items are available for **immediate shipment.**

Non-stock sizes of a round, oblong, square, hexagonal and rectangular shape of standard tooling will be **shipped within 48 hours.**

Model	Uses Punch	Uses Die
All Models	UHP	UHD
Oversize Combinations Over 1-1/2"	UHP2 No. 237	No. 420 No. 422 No. 490

Punches

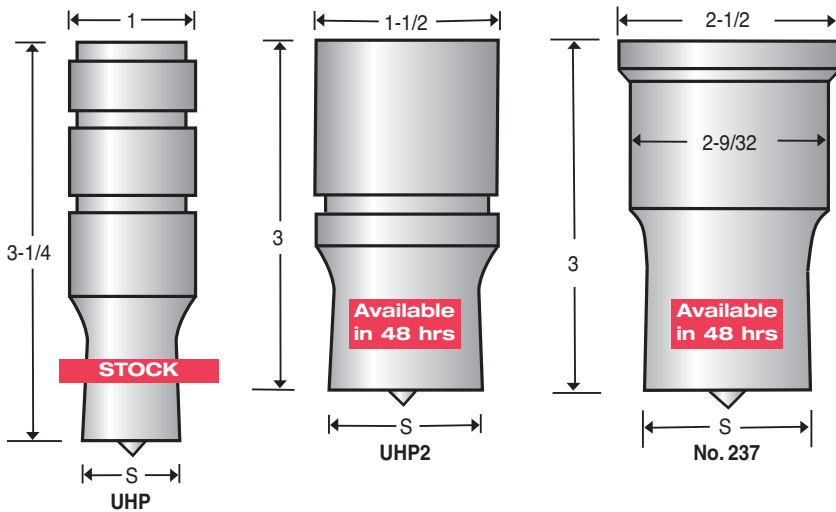

Stock Punch and Die Sizes

ROUND SIZES		OBLONG SIZES	
PUNCHES UHP	DIES UHD	PUNCHES UHP	DIES UHD
1/4	9/32	9/16 X 1	19/32 x 1-1/32
9/32	5/16	11/16 X 1	23/32 x 1-1/32
5/16	11/32	13/16 X 1	27/32 x 1-1/32
11/32	3/8		
3/8	13/32		
13/32	7/16		
7/16	15/32		
15/32	1/2		
1/2	17/32		
17/32	9/16		
9/16	19/32		
19/32	5/8		
5/8	21/32		
21/32	11/16		
11/16	23/32		
23/32	3/4		
3/4	25/32		
25/32	13/16		
13/16	27/32		
27/32	7/8		
7/8	29/32		
29/32	15/16		
15/16	31/32		
31/32	1		
1	1-1/32		

Dies

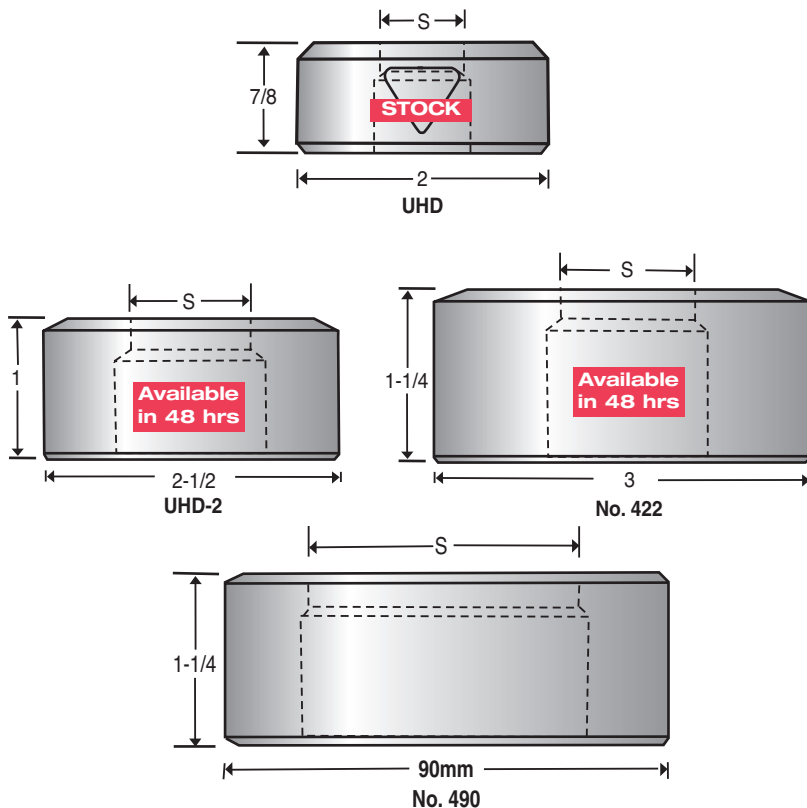

Coupling Nut

