

All stock items are available for **immediate shipment.**

Non-stock sizes of a round, oblong, square, hexagonal and rectangular shape of standard tooling will be **shipped within 48 hours.**

Model	Uses Punch	Uses Die
Single cylinder machines manufactured prior to 2000	No. 221 No. 228	No. 413 No. 419
Single cylinder machines	No. 221	No. 413
Dual cylinder machines	No. 228	No.419
Oversize	51mm, 60mm 80mm, 90mm 100mm	80mm, 110mm, 150mm, 200mm, 250mm

Punches

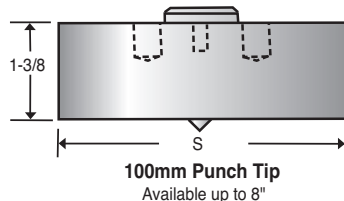
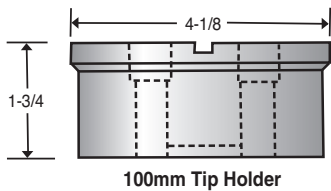
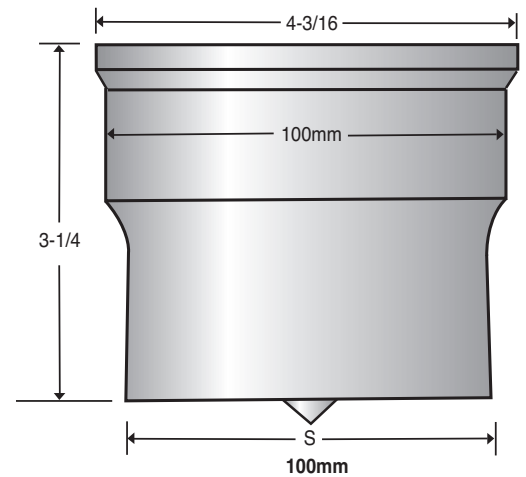
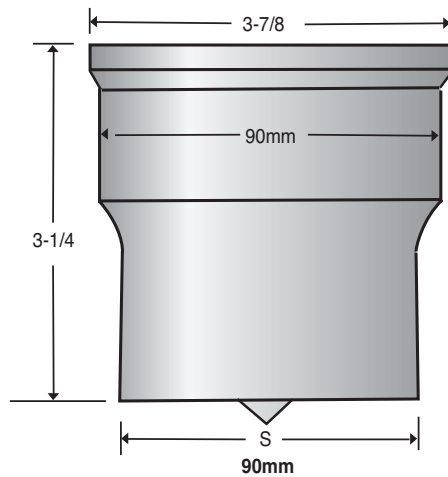
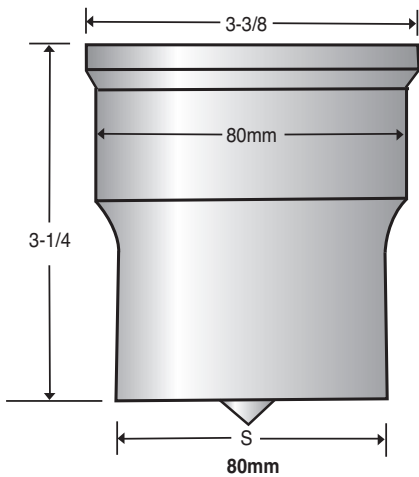
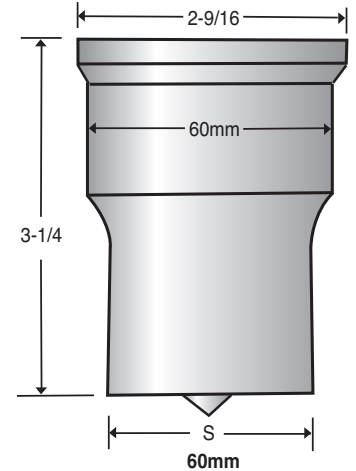
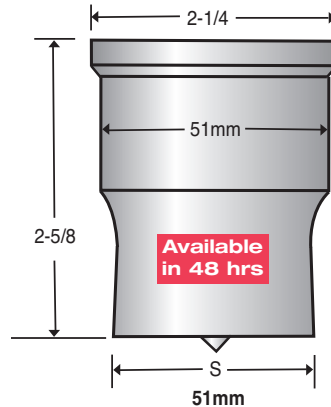
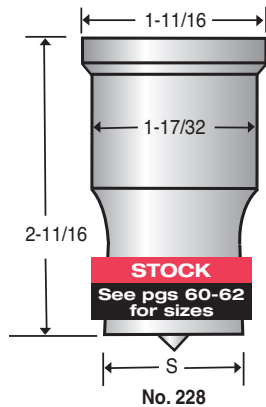
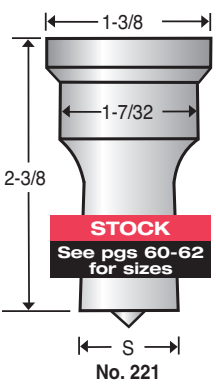

NOTE: Keyways are recommended for alignment of shaped punches. When ordering tooling, specify a Spartan Ironworker and a 1/4" wide x 1/8" deep keyway will be added to the head of shaped punches. If no machinery is specified, keyways will not be furnished.

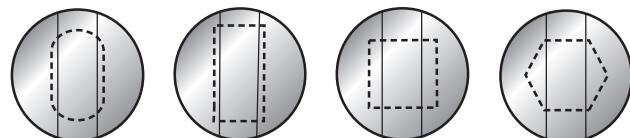
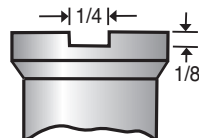

Standard Keyway Positions for Alignment of Shaped Punches

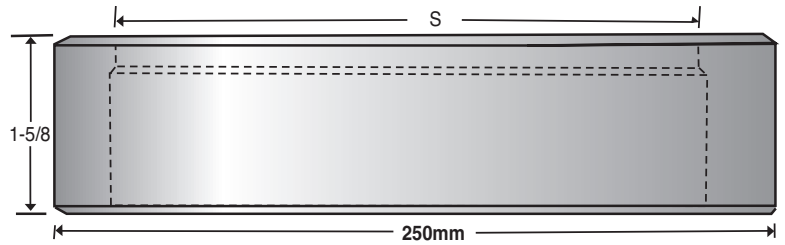
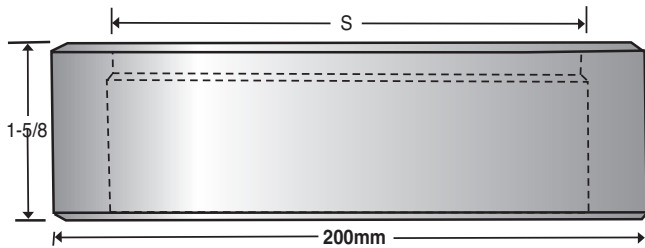
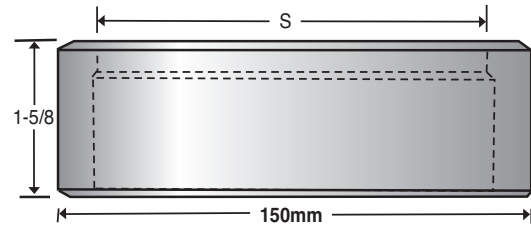
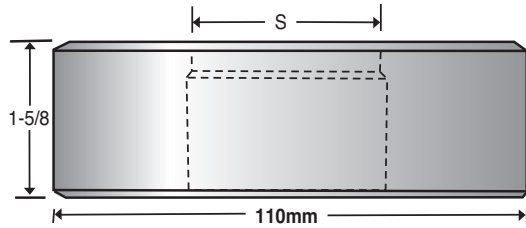
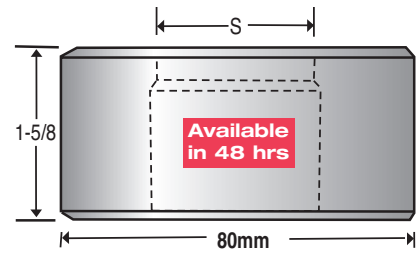
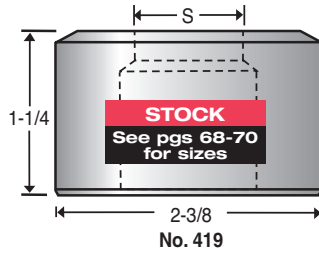
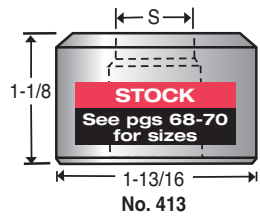

NOTE: Locating spots are recommended for alignment of shaped dies. When ordering tooling, specify a Spartan Ironworker and a set screw spot will be added to shaped dies. If no machinery is specified, keyways will not be furnished.

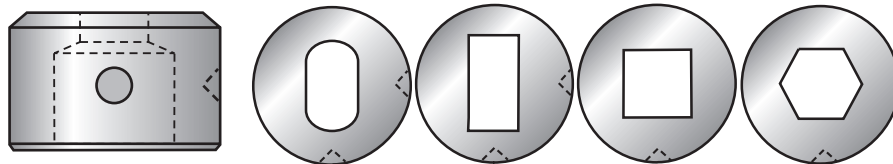

Standard Locating Spot Positions for Alignment of Shaped Dies