

All stock items are available for **immediate shipment.**

Non-stock sizes of a round, oblong, square, hexagonal and rectangular shape of standard tooling will be **shipped within 48 hours.**

Punches

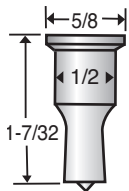

No. 61

STOCK
See pgs 60-62
for sizes

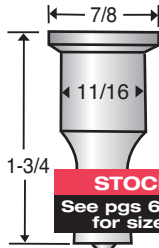

No. 62

STOCK
See pgs 60-62
for sizes

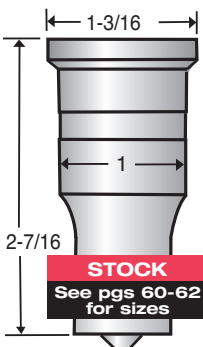

No. 63

STOCK
See pgs 60-62
for sizes

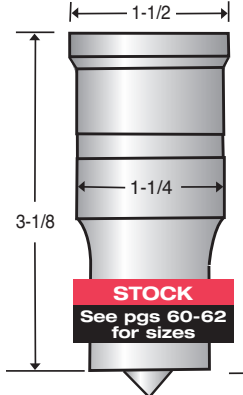

No. 64

STOCK
See pgs 60-62
for sizes

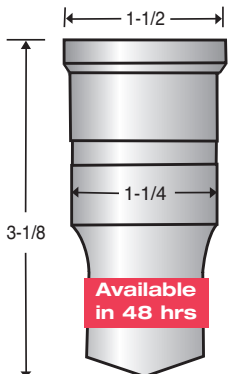

No. 64Y

Available in 48 hrs

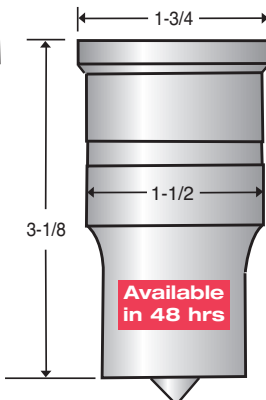

No. 65

Available in 48 hrs

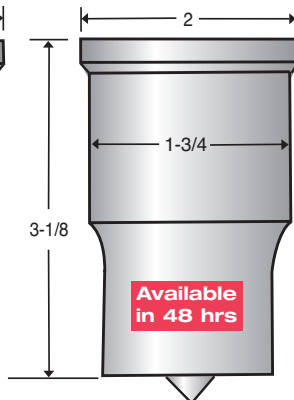

No. 292C

Available in 48 hrs

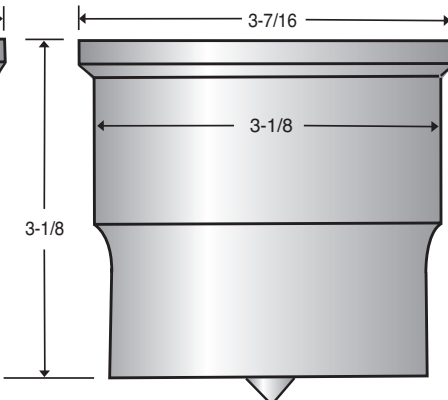

No. 67

▶ Peddinghaus Ironworkers	See previous page	
▶ Anglemaster	Uses Punch	Uses Die
Anglemaster	No. 64Y	No. 47/45
623, 645	No. 64	No. 47
643, 823	No. 64, No. 65	No. 47, No. 291
823B	No. 65	No. 291
1563, 2063	No. 64, No. 65	No. 47
▶ Fabripunch	Uses Punch	Uses Die
118, 120	No. 64, No. 65	No. 47
500/3, 1120, 1154, 1154-30	No. 64	No. 47 No. 47/45
	No. 65	No. 419 No. 419/45
600/3, 1170, 1500/3, 1800/3	No. 64 No. 292C	No. 47 No. 291
▶ Fabriline (Portables)	Uses Punch	Uses Die
FP6	No. 61	No. 49
FP12, FP20, FP20-4, FP20-6, WP20	No. 62	No. 48
FP35, FP35-8	No. 63	No. 47
FP35CC, WP35	No. 63	No. 48
FP45, FP60, FP80, FP80-9, FP100	No. 64, No. 65	No. 47
FP100-12, WP60, WP80, WP100, WP100-18, WP100-25	No. 64 No. 65	No. 47 No. 47F
Stationary 140	No. 292C	No. 421
WP140	No. 292C	No. 291
WP140-12-1/2, FP140-6-1/4, FP140-12-1/2	No. 67	No. 44
FP250-12-1/2	No. 67	No. 43
▶ Others	Uses Punch	Uses Die
7130 Duplicator	No. 64	No. 47
Beam Fabricator	No. 65	No. 47F
2000CNC BPL1000/5	No. 64, No. 65	No. 47, No. 419

Dies

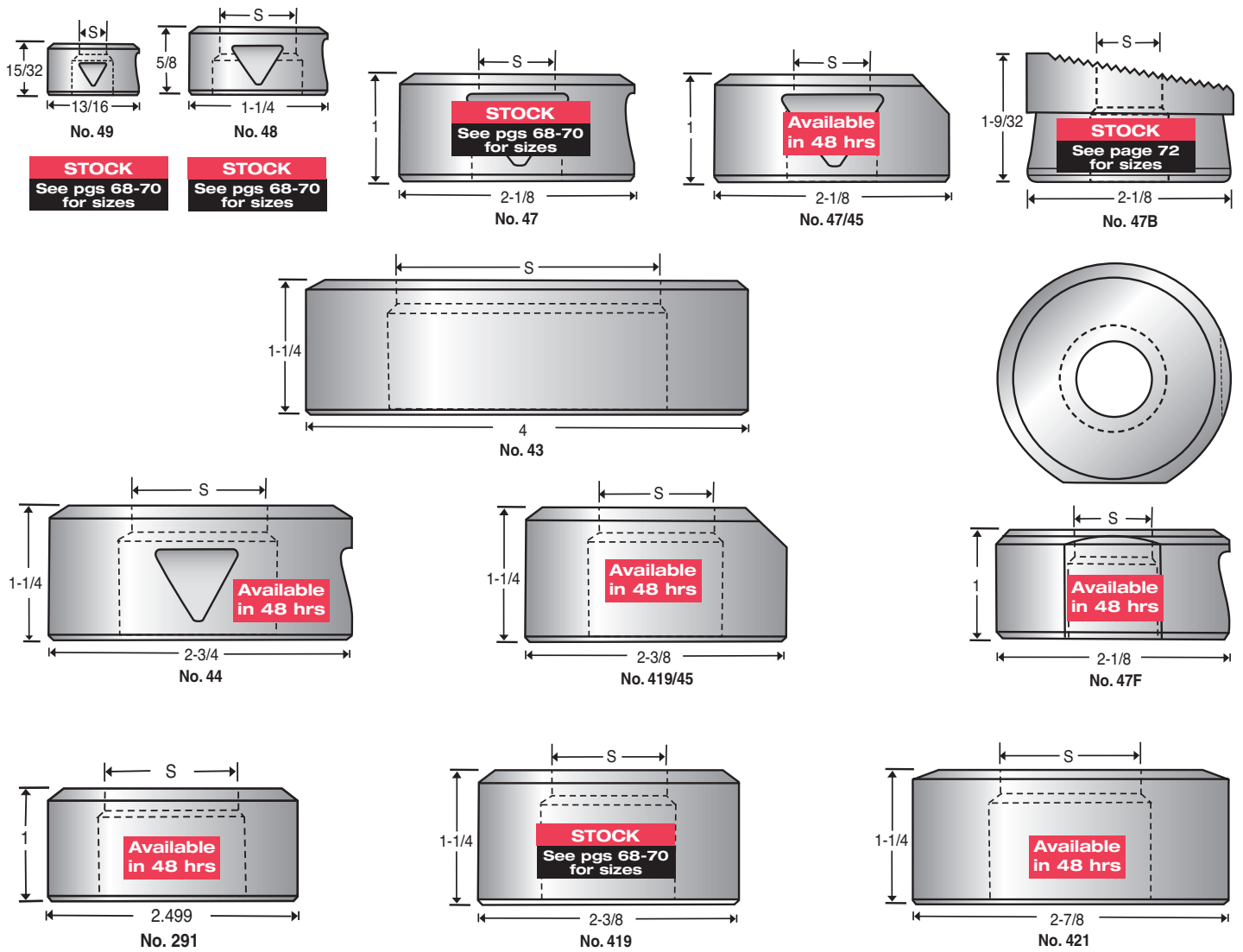

Shear Blades for Anglemaster

