

All stock items are available for **immediate shipment.**

Non-stock sizes of a round, oblong, square, hexagonal and rectangular shape of standard tooling will be **shipped within 48 hours.**

| Model | Uses Punch | Uses Die |
|--------------------------------------------------------------------------------------------------------------------------------------------------------------------------------------------------------------------------------------------|---------------------------------------|------------------------------------------------------|
| COMPACT 50, COMPACT 65 J14/A or B, J18/GXA or B, J21/GXA or B, J25/GXA or B 60DP, 75DP, 95DP, 125DP 60P625, 75P625, 95P625, 125P625, 175P625 50XA, 65XA 45XM 60XS, 75XS, 95XS, 125XS, 175XS SHARK ULTIMA MODELS | No. 221 No. 228 | No. 419 No. 417* |
| *Requires Die Adapter | | |
| Oversize | No. 237 No. 9010KND No. 9011KND | No. 422 No. 9024KND No. 9025KND No. 9026KND |

Punches

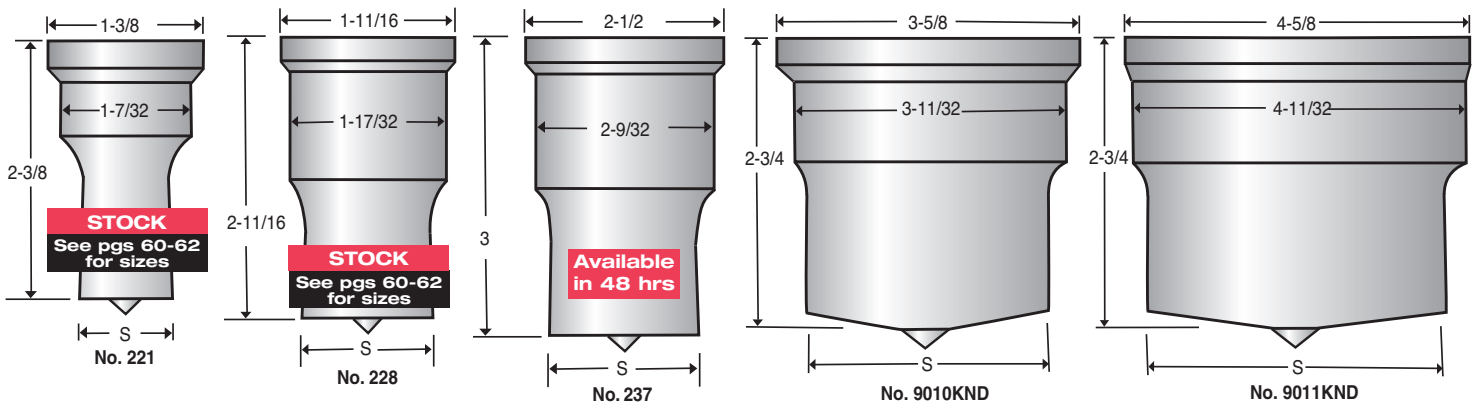

Dies

