

All stock items are available for **immediate shipment.**

Non-stock sizes of a round, oblong, square, hexagonal and rectangular shape of standard tooling will be **shipped within 48 hours.**

Model	Uses Punch	Uses Die
#3 Combination	No. 208	No. 408, No. 402
#3, #30, MW30	No. 216	No. 408, No. 402
#3A, #4, #4 Combination	No. 221	No. 408, No. 402
#4A, #5, #50, MW50, #6, #6A	No. 221	No. 417, No. 402, No. 408
#7, #7A, #7 Combination	No. 228	No. 419, No. 408

Punches

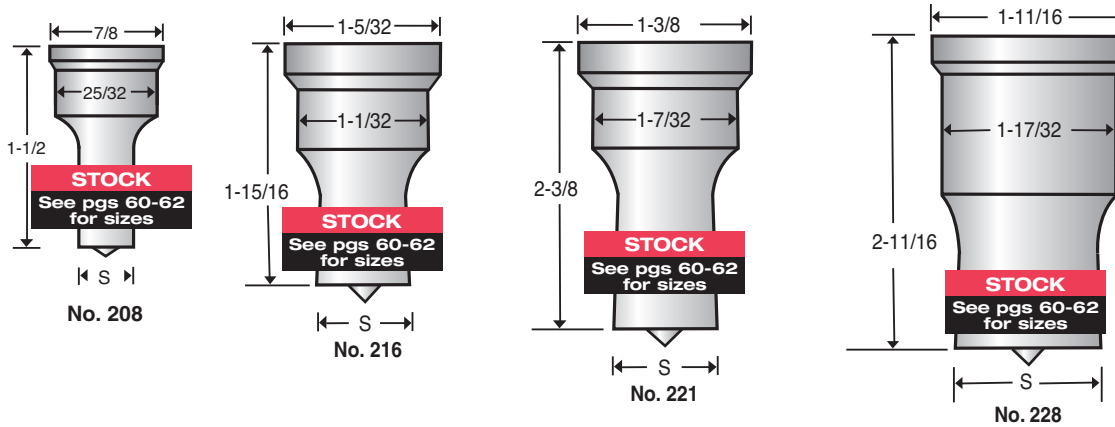

Dies

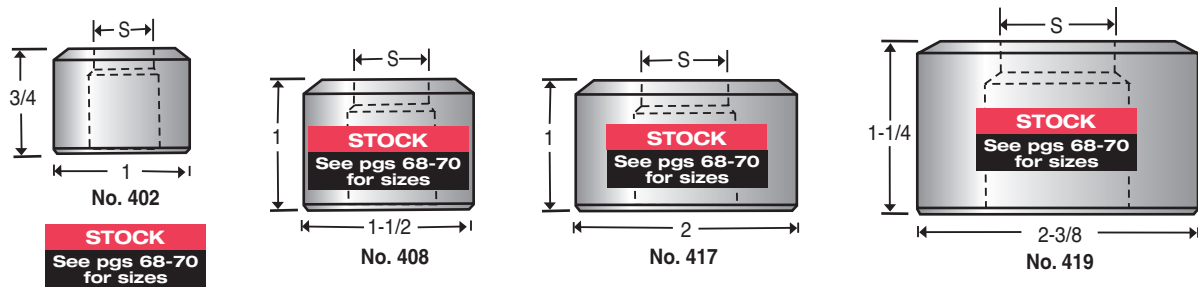

Coupling Nut

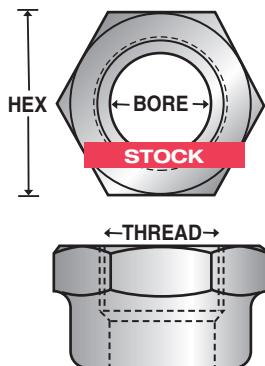

Stock Coupling Nuts

COUPLING NUT PART NO.	THREAD	BORE	HEX	FITS PUNCH
#7	1-1/16-12 UN	53/64"	1-11/16"	No. 208
#12	1-5/16-12 UN	1-5/64"	2"	No. 216
#17	1-9/16-12 UN	1-17/64"	2-1/4"	No. 221
#21	1-7/8-12 UN	1-37/64"	2-1/2"	No. 228