

All stock items are available for **immediate shipment.**

Non-stock sizes of a round, oblong, square, hexagonal and rectangular shape of standard tooling will be **shipped within 48 hours.**

Model	Uses Punch	Uses Die
Microcrop, Minicrop, Maxicrop 11 H, 13 H, CEP 11, CEP 13 Hydracrop 50, Hydracrop 70 PUMA 11, PUMA 13, PUMA 50H, PUMA 70H	No. 219	No. 417
Multi 11	No. 208	No. 405
16 H, 20 H, CEP 16, CEP 20 Hydracrop 55A, Hydracrop 100 PUMA 16, PUMA 20, PUMA100H	No. 221	No. 417
25 H, Hydracrop 150, Hydracrop 165, Hydracrop 200, Hydracrop 220, PUMA 150H, PUMA 165H, PUMA 200H, PUMA 220H	No. 228	No. 421
PUMA 55H, PUMA 80 Dual Static, 55A, 80A	No. 221 and No. 228S	No. 417 and 60mm
PUMA 110 H, PUMA 110 A Hydracrop 110	No. 221 and No. 228	No. 417 and No. 421
▶ Oversize	No. 11, No. 12, No. 13, No. 13 Two Piece	No. 11, No. 12, No. 13, No. 421 200mm

Punches

Standard Punches

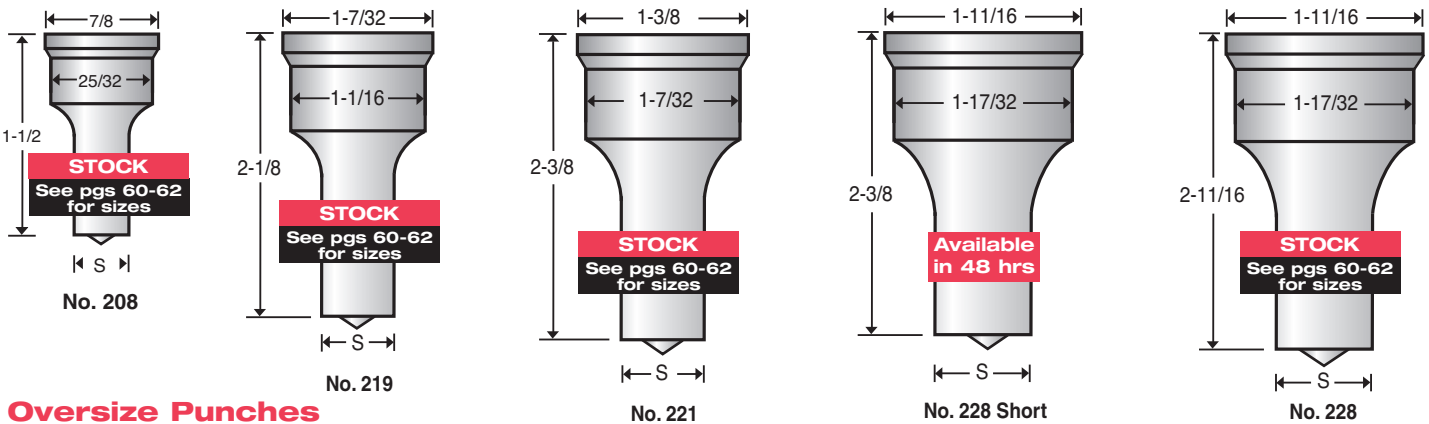

Oversize Punches

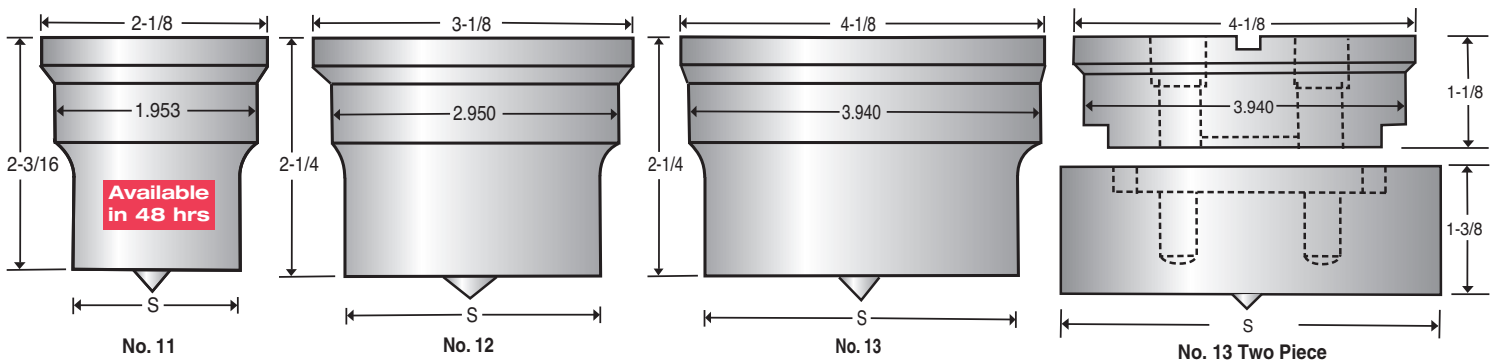

NOTE: Keyways are recommended for alignment of shaped punches. When ordering tooling, specify a Geka Ironworker and a metric keyway will be added to the head of shaped punches. If no machinery is specified, keyways will not be furnished.

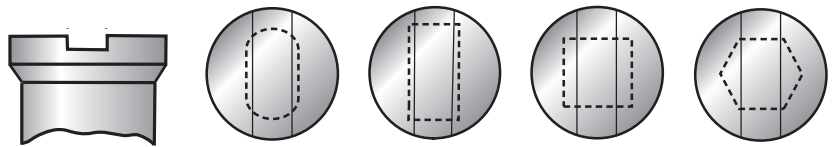

Dies

Standard Dies

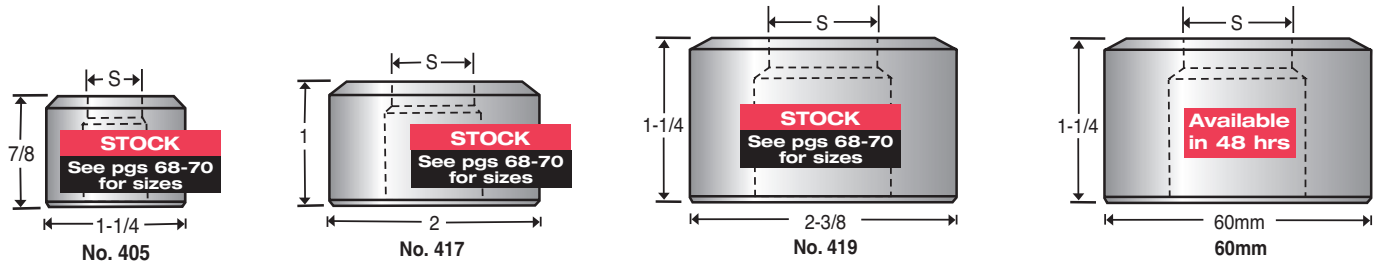

Oversize Dies

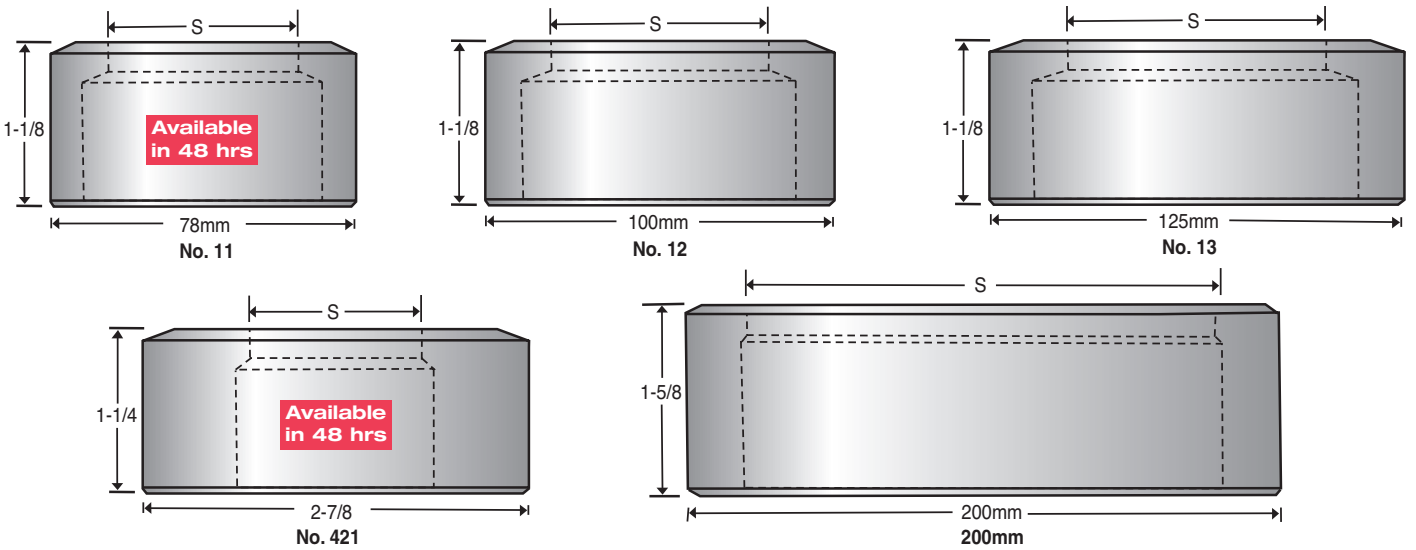

NOTE: Locating spots are recommended for alignment of shaped dies. When ordering tooling, specify a Geka Ironworker and a "V" groove will be added to shaped dies. If no machinery is specified, keyways will not be furnished.

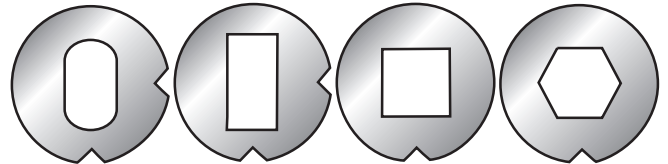
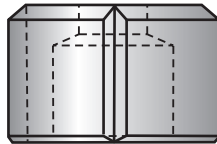

Standard Locating Spot Positions for Alignment of Shaped Dies

Miscellaneous Offset Tooling

