

All stock items are available for **immediate shipment.**

Non-stock sizes of a round, oblong, square, hexagonal and rectangular shape of standard tooling will be **shipped within 48 hours.**

► Portable Machines	Uses Punch	Uses Die
F530X3, W530X4	No. 63	No. 48
F550X4, F570X6, F5100X6 W550X7, W570X8, W5100X12	No. 64	No. 47
W5100X18, W5100X30	No. 64	No. 47
F5125X6, F5175X6, F5175X12 F5275X12, W5125X12, W5175X18	No. 66	No. 46
► Angle Fabricators		
AFC5106, AFC5108, AFC5138	No. 64	No. 47
► Beam Line		
BL100-5	No. 64	No. 47
► Plate Fabricator		
PF196X72G	No. 64 No. 66	No. 47 No. 46
► Structural Fabricator		
SF70A	No. 64	No. 47

Punches

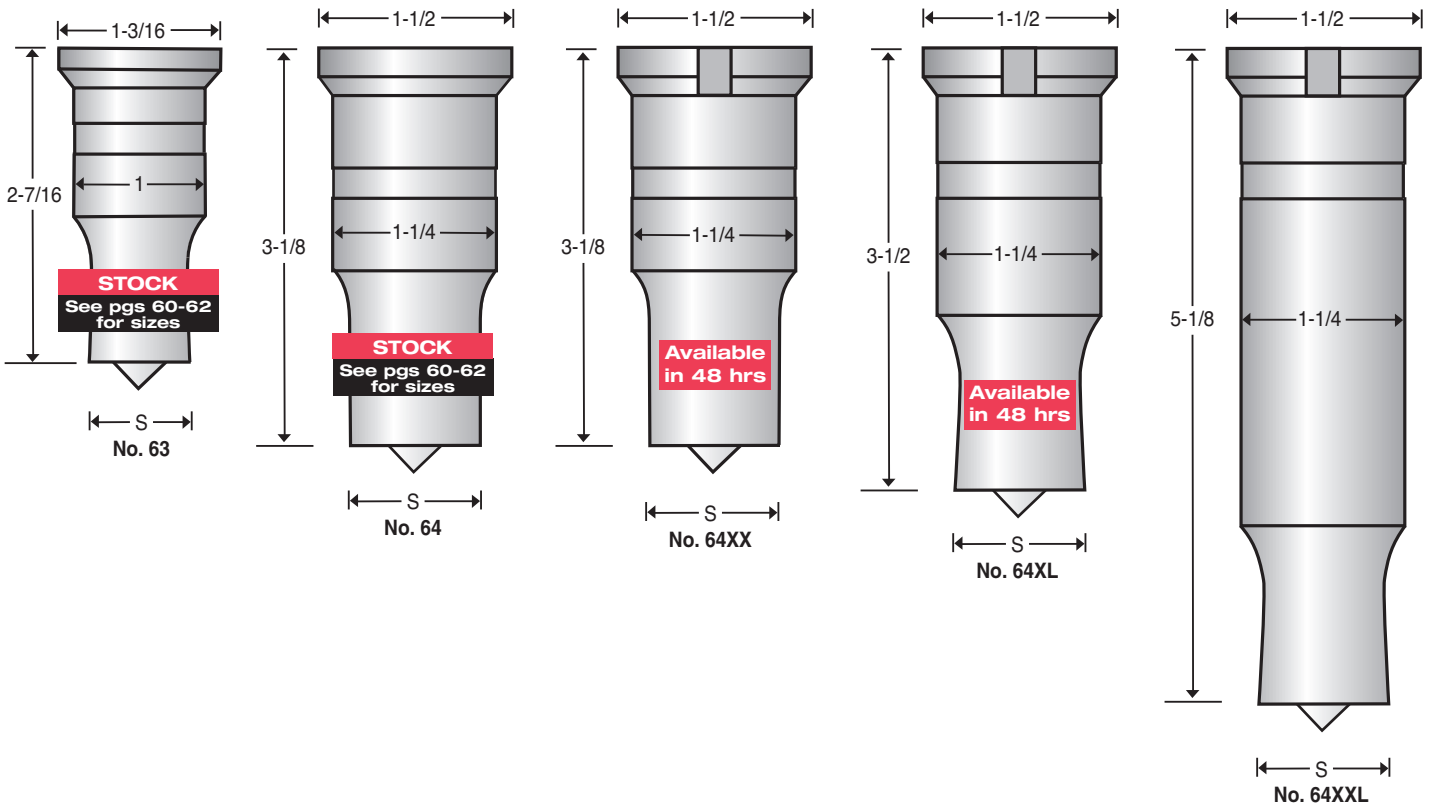

Punches (con't)

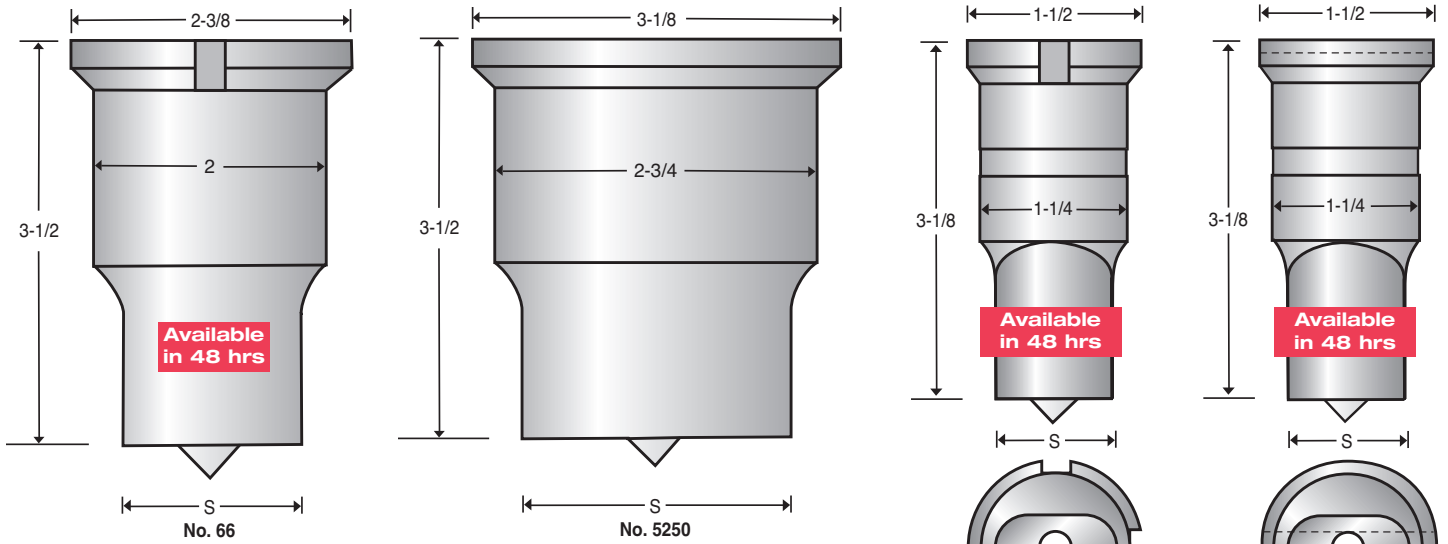

Dies

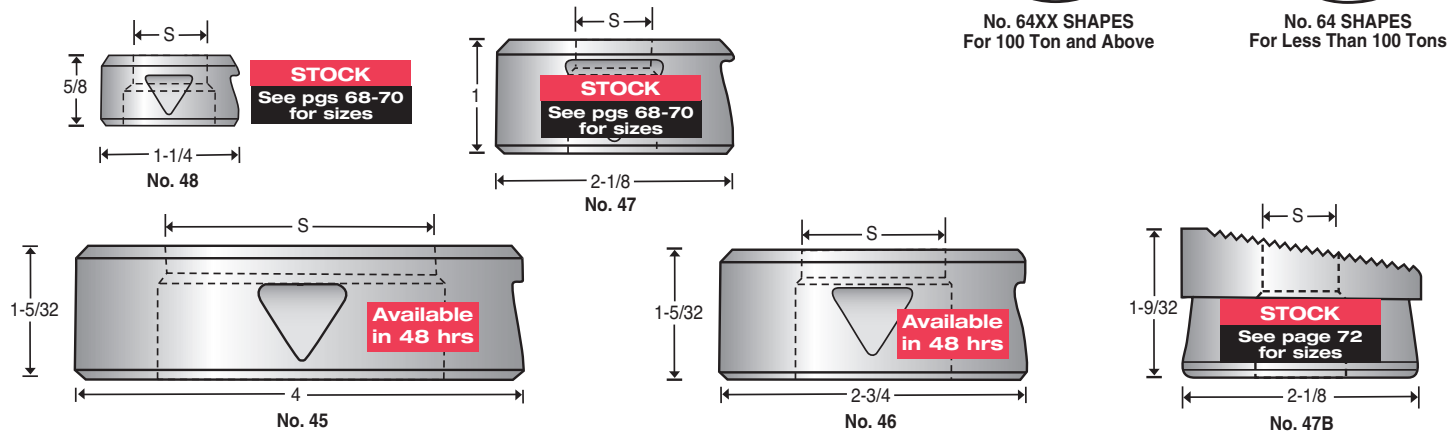

Angle Blades

Upper Blade 17276 • Stock Model #1504

Upper Blade C4159 • Stock Model #1506

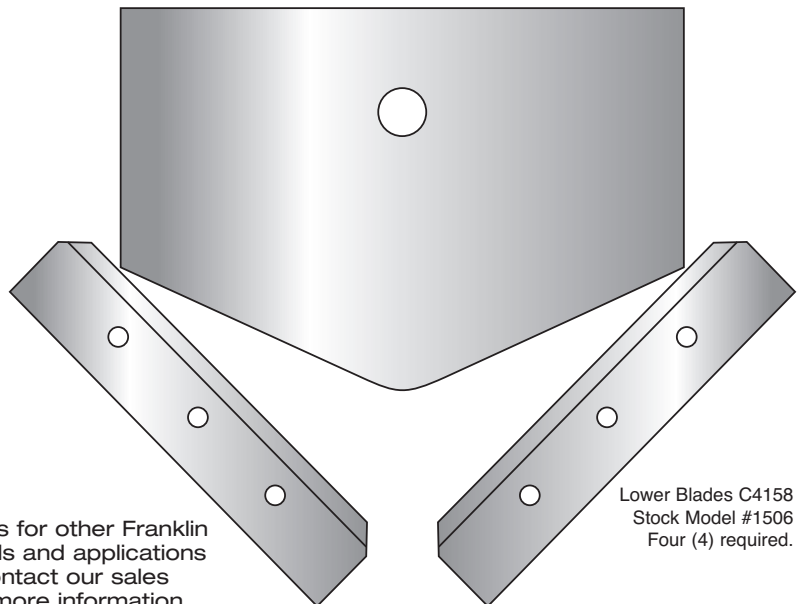
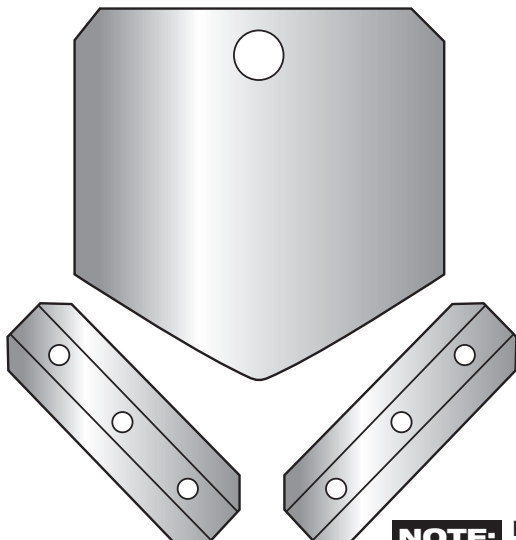

Lower Blades 17277
Stock Model #1504
Two (2) required.

NOTE: Blades for other Franklin models and applications are available. Contact our sales department for more information.

Lower Blades C4158
Stock Model #1506
Four (4) required.